

JADE™ Economizer Module

(MODEL W7220)

INSTALLATION INSTRUCTIONS



PRODUCT DESCRIPTION

The JADE™ Economizer System is an expandable economizer control system, which includes a W7220 Economizer Module (controller) with an LCD and keypad. The W7220 can be configured with optional sensors.

The W7220 Economizer Module can be used as a stand-alone economizer module wired directly to a commercial set back space thermostat and sensors to provide Outdoor Air dry-bulb economizer control.

The W7220 Economizer Module can be connected to optional Sylk Bus sensors for single or differential enthalpy control. The W7220 Economizer Module provides power and communications on the Sylk Bus for the Sylk Bus sensors.

The W7220 Economizer Module automatically detects sensors by polling to determine which sensors are present. If a sensor loses communications after it has been detected, the W7220 Economizer indicates a device fail error on its LCD.

System Components

The JADE™ Economizer System includes an Economizer Module, 20k mixed air sensor, damper actuator, an optional CO₂ sensor, and either a 20k outdoor air temperature sensor or Sylk Bus sensors for measuring Outdoor Air and return air enthalpy, temperature, and humidity.

Economizer Module

This is the core of the JADE™ Economizer System and includes the user interface for the system. The W7220 Economizer Module provides the basic inputs and outputs to provide simple economizer control. When used with the optional Sylk Bus sensors, the Economizer Module provides more advanced economizer functionality.

Sylk Bus Sensors (optional)

The Sylk Bus Sensor is a combination temperature and humidity sensor which is powered by and communicates on the Sylk Bus. Up to three sensors may be configured with the JADE™ Economizer Module. See page 2 for details.

CO₂ Sensor (optional)

A CO₂ sensor can be added for Demand Control Ventilation (DCV). Either an analog (2-10 Vdc) or a wall-mount Sylk bus TR40 CO₂ sensor can be used with the Jade economizer.

Contents

Product Description	1
Specifications	2
Before Installation	3
Installation and Setup	3
Mounting	3
Wiring	4
Wiring Application Examples	9
Interface Overview	18
Setup and Configuration	18
Checkout	31
Troubleshooting	32



PC MOD Tool (optional)

The PC MOD tool is connected to a personal computer and communicates with the Jade economizer controller via the Sylk bus. The W7220 PCMOD tool software is free and can be downloaded from the url in the Accessories section.

Some features on the Jade controller can only be enabled or disabled using the W7220 PC MOD tool. See the PC MOD tool options section in Table 5.

SPECIFICATIONS

W7220A Economizer Module

The module is designed for use with any Honeywell 2 to 10 Vdc or Honeywell Sylkbus communicating actuator. The module includes terminals for a CO₂ sensor, Mixed Air sensor, and an Outdoor Dry Bulb sensor. Enthalpy and other options are available with Sylk Bus sensors.

User Interface: Provides status for normal operation, setup parameters, checkout tests, and alarms and error conditions with a 2-line 16 character LCD display and a four button keypad.

Electrical

Rated Voltage: 20 to 30 Vac RMS; 50/60 Hz
Transformer: 100 VA maximum system input

Nominal Power Consumption (at 24 Vac, 60 Hz): 11.5 VA without sensors or actuators

Relay Digital Output Rating at 30 Vac (maximum power from Class 2 input only): 1.5A run;
3.5A inrush @ 0.45PF (200,000 cycles) or
7.5A inrush @ 0.45PF (100,000 cycles)

External Sensors Power Output: 21 Vdc +/- 5% @ 48mA

IMPORTANT

All inputs and outputs must be Class 2 wiring.

Inputs

SENSORS:

NOTE: A Mixed Air (MA) analog sensor is required on all W7220 units; either an Outdoor Air (OA) sensor for dry bulb change over or an OA Sylkbus sensor for outdoor enthalpy change over is required in addition to the MA sensor. An additional Return

Air (RA) Sylkbus sensor can be added to the system for differential enthalpy or dry bulb changeover. For differential dry bulb changeover a 20k ohm sensor is required in the OA and a Sylkbus sensor in the RA. Dip switch on RA Sylkbus sensor must be set in the RA position.

Dry Bulb Temperature (optional) and Mixed Air (required), C7250A:

2-wire (18 to 22 AWG);
Temperature range -40 to 150 °F (-40 to 65 °C).
Temperature accuracy -0°F/+2°F

Temperature and Humidity, C7400S1000 (optional):

Sylk Bus; 2-wire (18 to 22 AWG)
Temperature: range -40 to 150 °F (-40 to 65 °C)
Temperature accuracy -0°F/+2°F
Humidity: range 0 to 100% RH with 5% accuracy.

NOTE: Up to three (3) SYLK Bus sensors may be connected to the JADE™ Economizer module. For outdoor air (OA), return air (RA) and discharge (supply) air (DA).

DCV (CO₂) Sensor (C7232 or C7632):

2-10 Vdc control signal; minimum impedance >50k ohm.

4 Binary inputs:

1-wire 24 Vac + common GND (see page 6 for wiring details). 24 Vac power supply: 20 to 30 Vac 50/60Hz; 100 VA Class 2 transformer.

Outputs

Actuator signal: 2-10 Vdc; minimum actuator impedance is 2k ohm; Sylkbus two-wire output for Honeywell Sylkbus communicating actuators.

Exhaust fan, Y1, Y2 and AUX1 O:

All Relay Outputs (at 30 Vac):
Running: 1.5A maximum
Inrush: 7.5A maximum

Environmental

Operating Temperature: -40 to 150 °F (-40 to 65 °C).
Exception of display operation down to -4 °F with full recovery at -4 °F from exposure to -40 °F

Storage Temperature: -40 to 150 °F (-40 to 65 °C)

Shipping Temperature: -40 to 150 °F (-40 to 65 °C)

Relative Humidity: 5% to 95% RH non-condensing

ORDERING INFORMATION

When purchasing replacement and modernization products from your TRADELINE® wholesaler or distributor, refer to the TRADELINE® Catalog or price sheets for complete ordering number. If you have additional questions, need further information, or would like to comment on our products or services, please write or phone:

1. Your local Honeywell Environmental and Combustion Controls Sales Office (check white pages of your phone directory).
2. Honeywell Customer Care
1985 Douglas Drive North
Minneapolis, Minnesota 55422-4386
3. <http://customer.honeywell.com> or <http://customer.honeywell.ca>

International Sales and Service Offices in all principal cities of the world. Manufacturing in Belgium, Canada, China, Czech Republic, Germany, Hungary, Italy, Mexico, Netherlands, United Kingdom, and United States.

Dimensions (See Fig. 1 on page 3):

- Height: 4.98 inches (126.4 mm)
- Width: 6.3 inches (160 mm)
- Depth: 1.34 inches (34 mm)

Weight: 0.58 lb. (0.265 kg)

Approvals: UL listed (XAPX) for USA and Canada;
California Energy Commission (CEC) FDD ID number HJW10.

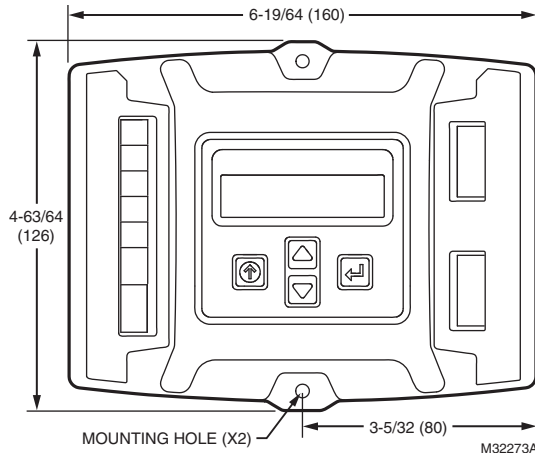

Fig. 1. Dimensions in inches (mm) showing mounting holes.

Accessories

- 50048926-001 2-pin edge connector for sensors (20 pieces per bag)
- 50048926-002 6-pin edge connector for field wiring (20 pieces per bag)
- C7250A 20k sensor for MA or OA (dry bulb change-over)
- C7400S Sylkbus sensor for enthalpy control in OA and/or RA and RA for differential dry bulb change-over
- W7220 PCMOD interface tool for JADE controller and Personal Computer. For the software, go to www.customer.honeywell.com/economizertools
- 50053060-001 Duct mounting kit for sensors
- C7632 or C7232 CO₂ analog sensors OR one TR40 Sylk bus CO₂ sensor

BEFORE INSTALLATION

Review the “Specifications” on page 2 before installing the The JADE™ Economizer System.

When Installing This Product

1. Read these instructions carefully. Failure to follow them could damage the product or cause a hazardous condition.
2. Check ratings given in instructions and on the product to ensure the product is suitable for your application.
3. Installer must be a trained, experienced service technician.
4. After installation is complete, check out product operation as provided in these instructions.

NOTE: Jade will be in the "set up" mode for the first 60 minutes after powered. If a sensor for OA air or Sylkbus device (sensor, actuator) is disconnected during the set up mode, the Jade will not alarm that failure. The MA sensor is a system "critical" sensor, if the MA sensor is removed during the set up mode, the Jade will alarm. After 60 minutes the Jade controller will change to operation mode and all components removed or failed will alarm in the operation mode.

INSTALLATION AND SETUP

The following installation procedures should be performed in the order listed:

1. Mounting – see page 3.
2. Wiring – see page 4.
3. Interface and Programming overview – see page 18.
4. Setup and Configuration – see page 18
5. Checkout – see page 31.

Troubleshooting and Alarms—see page 32.

MOUNTING

This section describes the mounting procedures for the JADE™ Economizer module and the sensors.

Economizer Module Location and Mounting

IMPORTANT

Avoid mounting in areas where acid fumes or other deteriorating vapors can attack the metal parts of the module’s circuit board, or in areas where escaping gas or other explosive vapors are present.

IMPORTANT

The module must be mounted in a position that allows clearance for wiring, servicing, and removal.

Mount the Economizer module on any convenient interior location using the two mounting holes provided on the enclosure using #6 or #8 screws (screws are not provided and must be obtained separately). Use the dimensions in Fig. 1 on page 3 as a guide.

The Economizer module may be mounted in any orientation. However, mounting in the orientation shown in Fig. 1 on page 3 permits proper viewing of the LCD display and use of the keypad.

Sensor Location and Mounting

The JADE™ Economizer W7220 uses digital and communicating sensors for control. The C7250 temperature sensors (MA^a and OA^b) are 20k NTC. A MA

^a MA = Mixed Air
^b OA = Outdoor Air

sensor is required for all applications and is mounted in the mixed air section of a rooftop unit either directly to the sheet metal using self tapping sheet metal screws or in the air stream using the duct mounting kit. Duct mount kit is part number 50053060-001.

Optional OA, RA^a and DA^b Sylkbus sensors communicate with the W7220 on the two-wire communication bus and can either be wired using a two pin header or using a side connector. Each Sylkbus sensor includes a two pin side connector with the packaging. The SKU number of the Sylkbus sensor is C7400S. All OA, RA and DA sensors are the same SKU number. The sensor is set for the appropriate type of sensing using the three position DIP switch located on the sensor. OA position is OFF, OFF, OFF; RA is ON, OFF, OFF and DA is OFF, ON, OFF. During installation the sensors are set for the usage desired. See “Sylk Bus Sensor Wiring” on page 7 for DIP switch details.

NOTE: The protective film on the dip switch is only necessary during the factory assembly process. Simply push through the film to set the dip switches; this will not harm the device.

Once installed, a sensor can be changed to a different application by simply changing the DIP switch setting.

Sensor Mounting

The sensors can be mounted directly on to the sheet metal of unit or can be mounted in the air stream using the duct mounting kit (order separately).

The kit contains a rod to hold the sensor in the duct, a flange to secure the sensor rod to the duct wall and fill the hole and a gasket to prevent air from leaking through the duct wall. There are five (5) kits in each bag assembly. See Fig. 2.

The rod has slots for threading the wire to prevent loose or hanging wire in the duct and can be adjusted for 6 to 12 inch length. The flange has extended relief for ease of mounting. See Fig. 3.

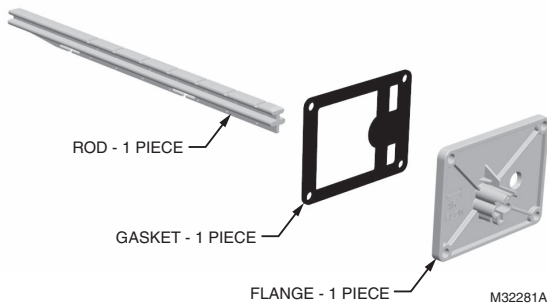

Fig. 2. Duct Mounting Kit (Part No. 50053060-001).

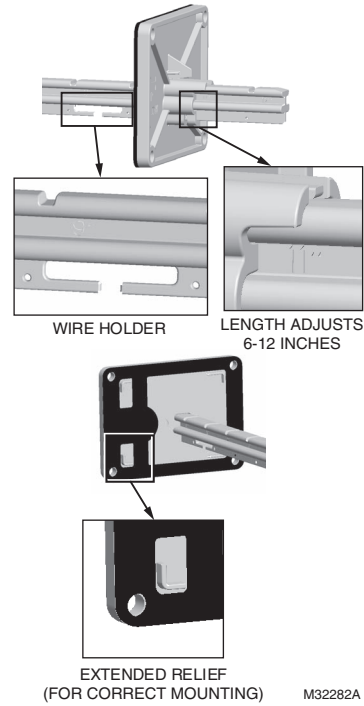

Fig. 3. Duct Mounting Adjustments.

WIRING

All wiring must comply with applicable electrical codes and ordinances, or as specified on installation wiring diagrams. Module wiring in the field is terminated to the four screw terminal blocks located on the left and right sides.

Module wiring at the OEM factory is terminated via the header pin terminals located on the left and right sides. The header terminal pins and the terminal blocks have common terminations for the appropriate input or output. See OEM wiring diagram in Fig. 20.

The remainder of this section describes the wiring for the JADE™ Economizer module, W7220A.



WARNING

Electrical Shock Hazard.
Can cause severe injury, death or property damage.

Disconnect power supply before beginning wiring, or making wiring connections, to prevent electrical shock or equipment damage.



CAUTION

Equipment Damage Hazard.
Electrostatic discharge can short equipment circuitry.

Ensure that you are properly grounded before handling the unit.

^a RA = Return Air
^b DA = Discharge Air

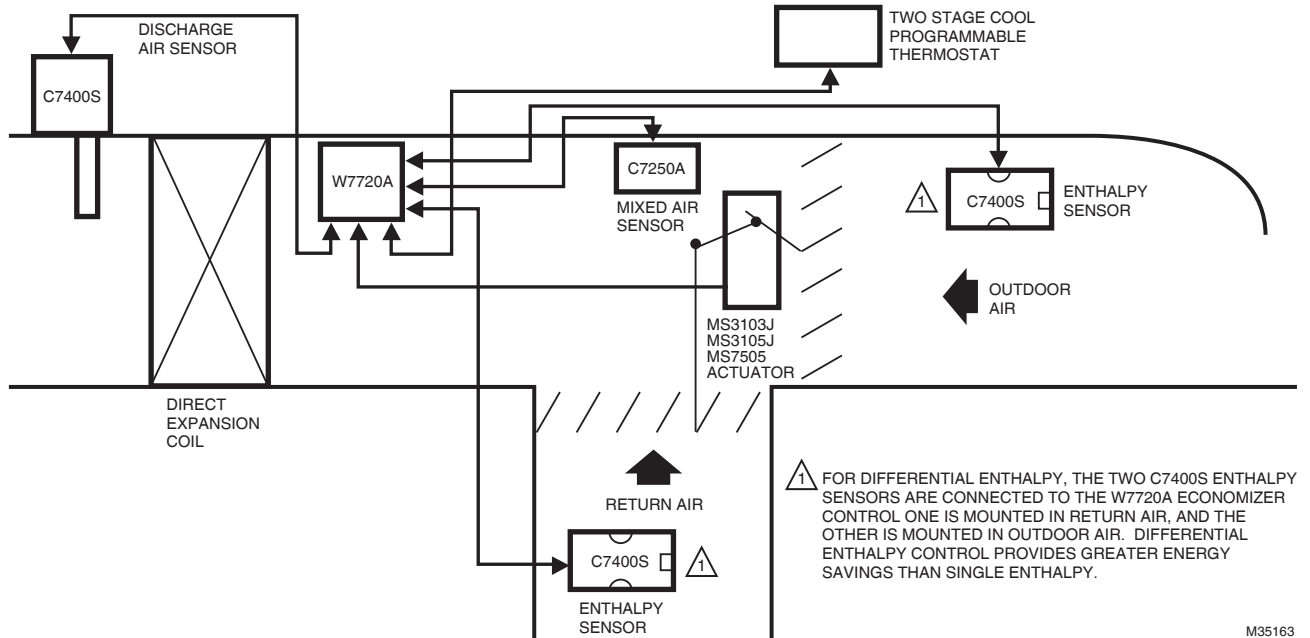

Fig. 4. Location of Outdoor Air, Return Air, Mixed Air, and Discharge Air Sensors in an economizer system.

Economizer Module Wiring Method

Wire the sensors and outputs, then wire the power connection.

Each terminal can accommodate the following gauges of wire:

- Single wire – from 18 AWG to 22 AWG solid or stranded
- Multiple wires – up to two 22 AWG stranded
- For the 24 Vac connections: single wire – from 14 to 18 AWG solid or stranded
- For S-BUS wiring, the sensors may be mounted up to 200 ft. (61 m) from the JADE controller. When the length of wire is over 100 feet use twisted pair shielded wire.
- All sensor wiring to the Sylk bus and analog sensors is polarity insensitive.

Prepare wiring for the terminal blocks, as follows:

1. Remove the plastic tabs from the side of the controller where the connectors will slide onto the PWA.
2. Strip 1/2 in. (13 mm) insulation from the conductor.
3. Cut a single wire to 3/16 in. (5 mm). Insert the wire in the required terminal location and tighten the screw.
4. If two or more wires are being inserted into one terminal location, twist the wires together a minimum of three turns before inserting them to ensure proper electrical contact. See Fig. 5 on page 6.
5. Cut the twisted end of the wires to 3/16 in. (5 mm) before inserting them into the terminal and tightening the screw.
6. Pull on each wire in all terminals to check for good mechanical connection.

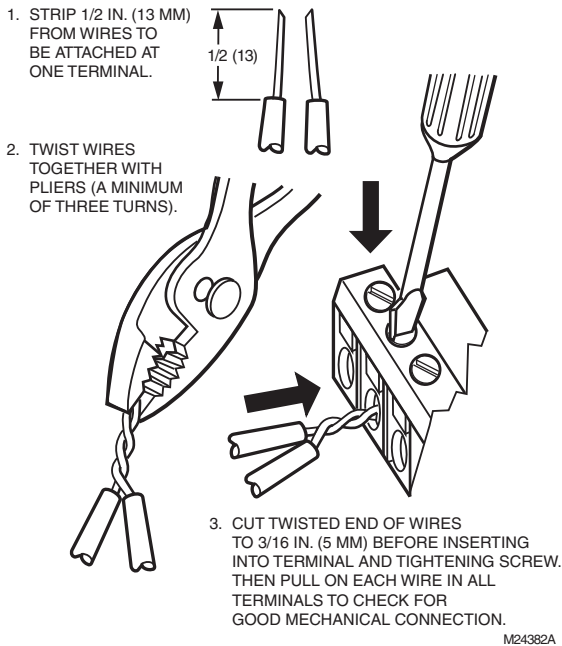

Fig. 5. Attaching two or more wires at terminal blocks.

Economizer Module Wiring Details

The wiring connection terminals for each module/sensor are:

- “JADE™ Economizer Module Wiring” on this page.
- “SyLK Bus Sensor Wiring” on page 7.

JADE™ Economizer Module Wiring

Use Fig. 6 and Tables 1 and 2 to locate the wiring terminals for the Economizer module.

NOTE: The four terminal blocks are removable. You can slide out each terminal block, wire it, and then slide it back into place.

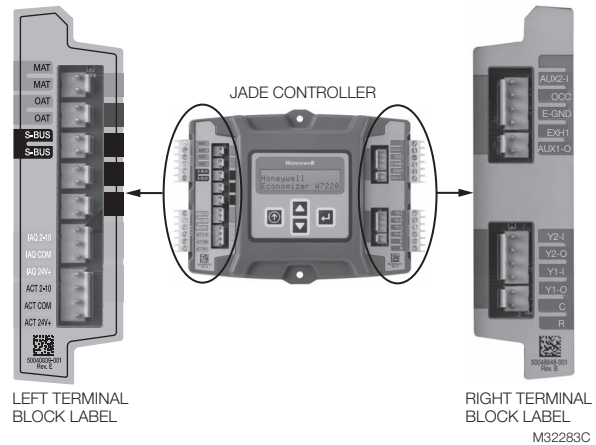

Fig. 6. W7220 Economizer module terminal connection labels.

Table 1. Economizer Module - Left hand terminal blocks.

Label	Type	Description
Top Left Terminal Block		
MAT MAT	20k NTC and COM	Mixed Air Temperature Sensor (polarity insensitive connection)
OAT OAT	20k NTC and COM	Outdoor Air Temperature Sensor (polarity insensitive connection)
S-BUS S-BUS	SYLK Bus	SyLK Bus sensor (polarity insensitive connection)
Bottom Left Terminal Block		
IAQ 2-10	2-10 Vdc	Air Quality Sensor Input (e.g. CO ₂ sensor)
IAQ COM	COM	Air Quality Sensor Common
IAQ 24V	24 Vac	Air Quality Sensor 24 Vac Source
ACT 2-10	2-10 Vdc	Damper Actuator Output (2-10 Vdc)
ACT COM	COM	Damper Actuator Output Common
ACT 24V	24 Vac	Damper Actuator 24 Vac Source
	n/a	The bottom pin is not used.

Table 2. Economizer Module - Right hand terminal blocks.

Label	Type	Description
Top Right Terminal Block		
	n/a	The first pin is not used
AUX2 I	24 Vac IN	Shut Down (SD) or Heat (W) Conventional only or Heat Pump Changeover (O/B) in Heat Pump mode.
OCC	24 Vac IN	Occupied / Unoccupied Input
E-GND	EGND	Earth Ground - System Required
EXH1	24 Vac OUT	Exhaust Fan 1 Output
AUX1 O	24 Vac OUT	Programmable: Exhaust fan 2 output or ERV or System Alarm output.
Bottom Right Terminal Block		
Y2-I	24 Vac IN	Y2 in - Cooling Stage 2 Input from space thermostat
Y2-O	24 Vac OUT	Y2 out - Cooling Stage 2 Output to stage 2 mechanical cooling
Y1-I	24 Vac IN	Y1 in - Cooling Stage 1 Input from space thermostat
Y1-O	24 Vac OUT	Y1 out - Cooling Stage 1 Output to stage 1 mechanical cooling
C	COM	24 Vac Common
R	24 Vac	24 Vac Power (Hot)

Sylk Bus Sensor Wiring

The labels on the sensors and controller are color coded for ease of installation. Orange labeled sensors can only be wired to orange terminals on the controller. Brown labeled sensors can only be wired to S-bus (brown) terminals. Use Fig. 7 and Table 3 to locate the wiring terminals for each Sylk Bus sensor.

Use Fig. 7 and Table 4 to set the DIP switches for the desired use of the sensor.

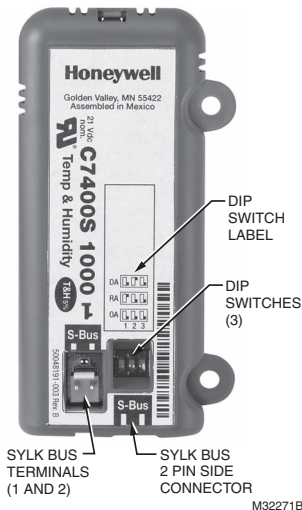

Fig. 7. Sylk Bus sensor DIP switches.

Table 3. SYLK Bus Sensor Wiring Terminations.

Terminal		Type	Description
Nbr	Label		
1	S-BUS	SYLK Bus	Sylk Bus Communications (Sensor Bus) polarity insensitive
2	S-BUS	SYLK Bus	Sylk Bus Communications (Sensor Bus) polarity insensitive

Table 4. SYLK Bus Sensor DIP Switch Settings.

Use	DIP Switch Positions for Switches 1, 2, & 3		
	1	2	3
DA ^a	OFF	ON	OFF
RA ^b	ON	OFF	OFF
OA ^c	OFF	OFF	OFF

^a DA = Discharge Air

^b RA = Return Air

^c OA = Outdoor Air

NOTE: When using the Sylkbus sensors there will be a slight delay while the Jade controller and the sensor communicate. Analog sensors do not communicate on the Sylkbus and output a 20k ohm signal to the Jade controller so the response time is instantaneous.

NOTE: When using the C7400S (Sylk bus enthalpy) sensor there is an operation that will allow test of the operation of the W7220 economizer when the outdoor air conditions (temperature and humidity) are too high for economizing.

1. Remove the C7250A dry bulb sensor from the OAT terminals IF you are using temperature only economizing change over.
2. If you are using enthalpy change over and have a C7400S sensor with a date code prior to 1301, remove the sensor and replace it with one with a date code after 1301.
3. Connect a C7400S Sylk bus sensor to the S-Bus terminals (brown colored) on the W7220A Jade using 18 AWG to 22 AWG solid or stranded wires.
4. Check the STATUS screen for actual outdoor air (OA) temperature and OA humidity readings.
5. Change the 3-position DIP switch on the C7400S sensor from 1 OFF, 2 OFF, 3 OFF to 1 ON, 2 ON, 3 ON position and immediately back to 1 OFF, 2 OFF 3 OFF position.
6. The output of the C7400S sensor to the W7220A will be 40 °F and 40 %RH which will allow the economizer to go into free cooling mode (economizing available).
7. Make sure you have 24 Vac on terminal Y1 In to simulate a call for cooling.
8. After 15 minutes the C7400S sensor will change back to the actual OA temperature and humidity.

NOTE: If you removed a dry bulb sensor, remove the C7400S from the S-bus terminals and replace the OAT sensor onto the OAT terminals.

Actuator Wiring Options:

1. The JADE economizer controller can only have one (1) communicating actuator connected to it.
2. Up to four (4) non-communicating and two (2) 2-position actuators (1 each on EXH1 and AUX1 O)
3. One (1) communicating and up to four (4) non-communicating and two (2) 2-position actuators (1 each on EXH1 and AUX1 O). When using a 2-position actuator on the AUX1 O, the AUX1 O must be programmed for Exh2 and the % open is the % open of the outdoor damper when the 2-pos actuator opens. Connect 24 V to Exh1 and/or AUX1 O and ground to the Jade "C" terminal.

CO2 Sensor Wiring

When using the C7232 Honeywell CO₂ sensors the black and brown common wires are internally connected and only one is connected to "IAQ COM" on the Jade. Use the power from the Jade to power the CO₂ sensor OR make sure the ground for the power supplies are common. See wiring diagram below for the C7232 and C7632 wiring diagrams.

NOTE: When using the C7632 (or any 0-10 Vdc CO₂ sensor) with the Jade you will need to set the CO2ZERO to 400 ppm and the CO2SPAN to 1600 ppm in the ADVANCED SETUP menu.

NOTE: When using the TR40 CO₂ sensor set the address on the TR40-CO2 to 6. Only one TR40 CO₂ sensor can be used with the Jade economizer controller. Address 6 is for a CO₂ sensor, address 11 is for a communicating actuator.

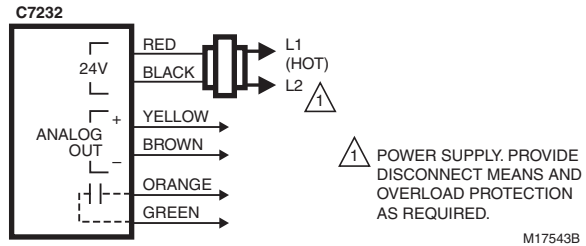

Fig. 8. Wiring for C7232

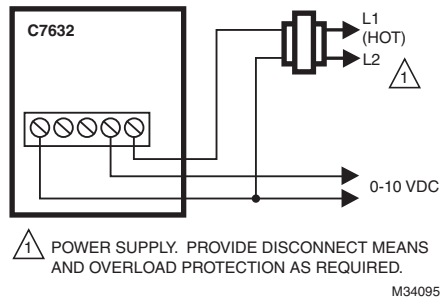

Fig. 9. Wiring for C7632

WIRING APPLICATION EXAMPLES

This section shows the wiring configurations for the JADE™ Economizer system.

Stand-alone Economizer

The most basic configuration is the stand-alone Economizer (see Fig. 10 and Fig. 15).

A stand-alone Economizer is directly wired to sensors, actuators, thermostat, and mechanical cooling controls in the roof top unit. It does not require Sylk Bus communications.

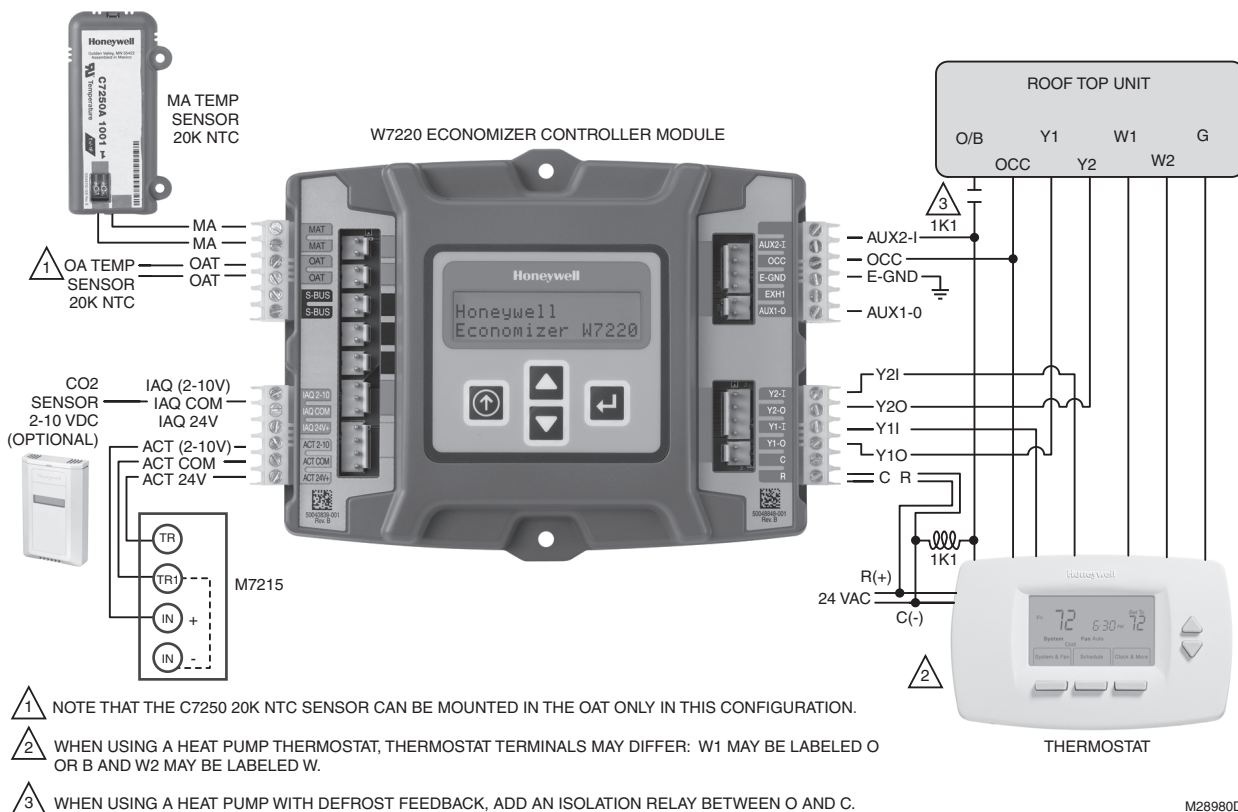
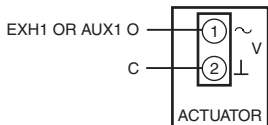

Fig. 10. Stand-alone dry bulb Economizer configuration with black motor M7215.



NOTE: ON/OFF ACTUATORS CAN BE USED ON THE EXH1 OR AUX1 O TERMINAL WITH GROUND TO THE C TERMINAL. WHEN PROGRAMMING THE EXH1 OR AUX1 O, THE % IS THE PERCENT OPEN POSITION OF THE OUTDOOR AIR DAMPER WHEN THE EXH1 OR AUX1 O TERMINAL IS ENERGIZED AND THE 2-POS DAMPER GOES OPEN. IF USING THE AUX1 O TERMINAL PROGRAM AUX1 O FOR EXH2.

M33409

Fig. 11. 2-position actuator.

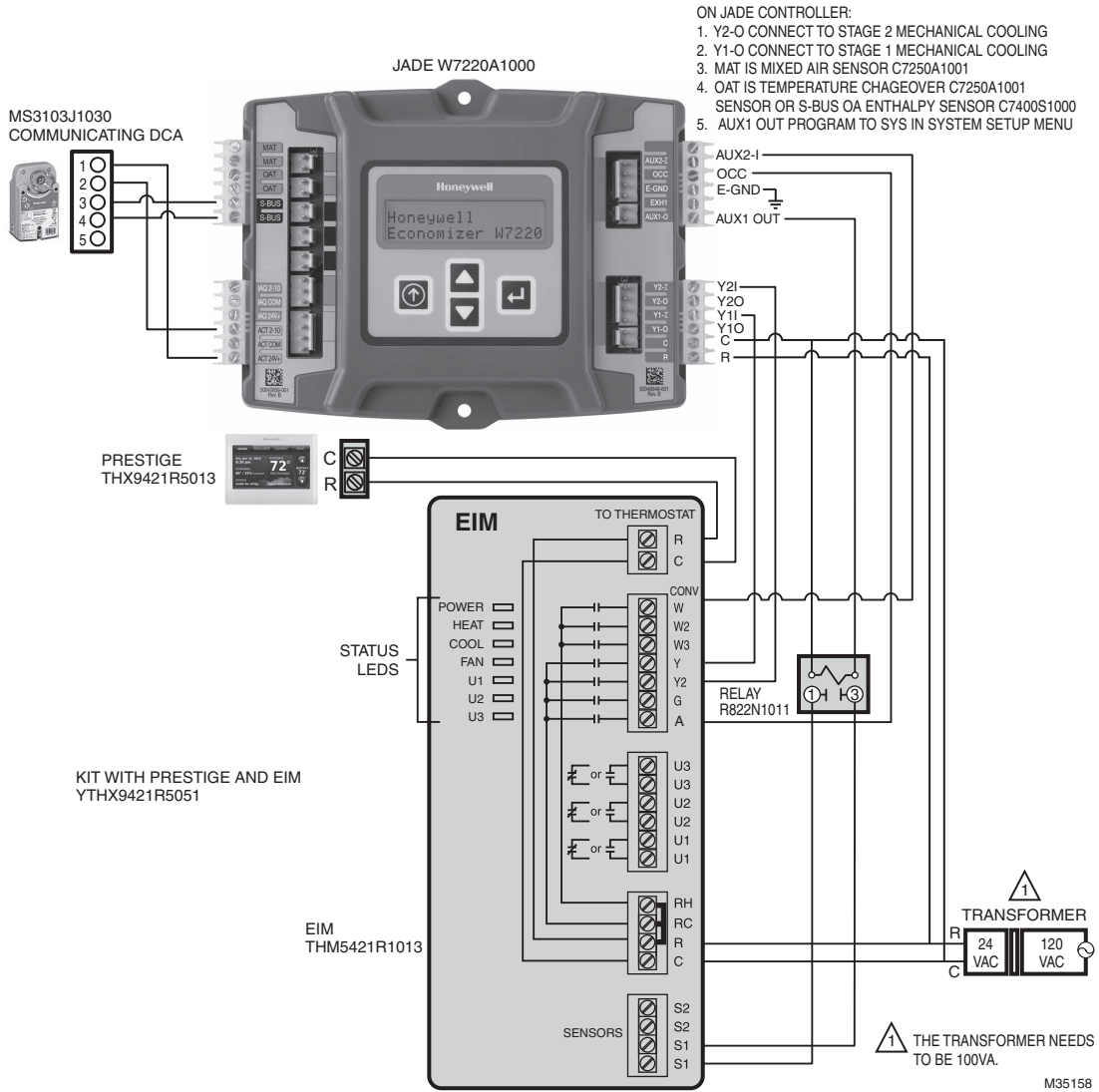
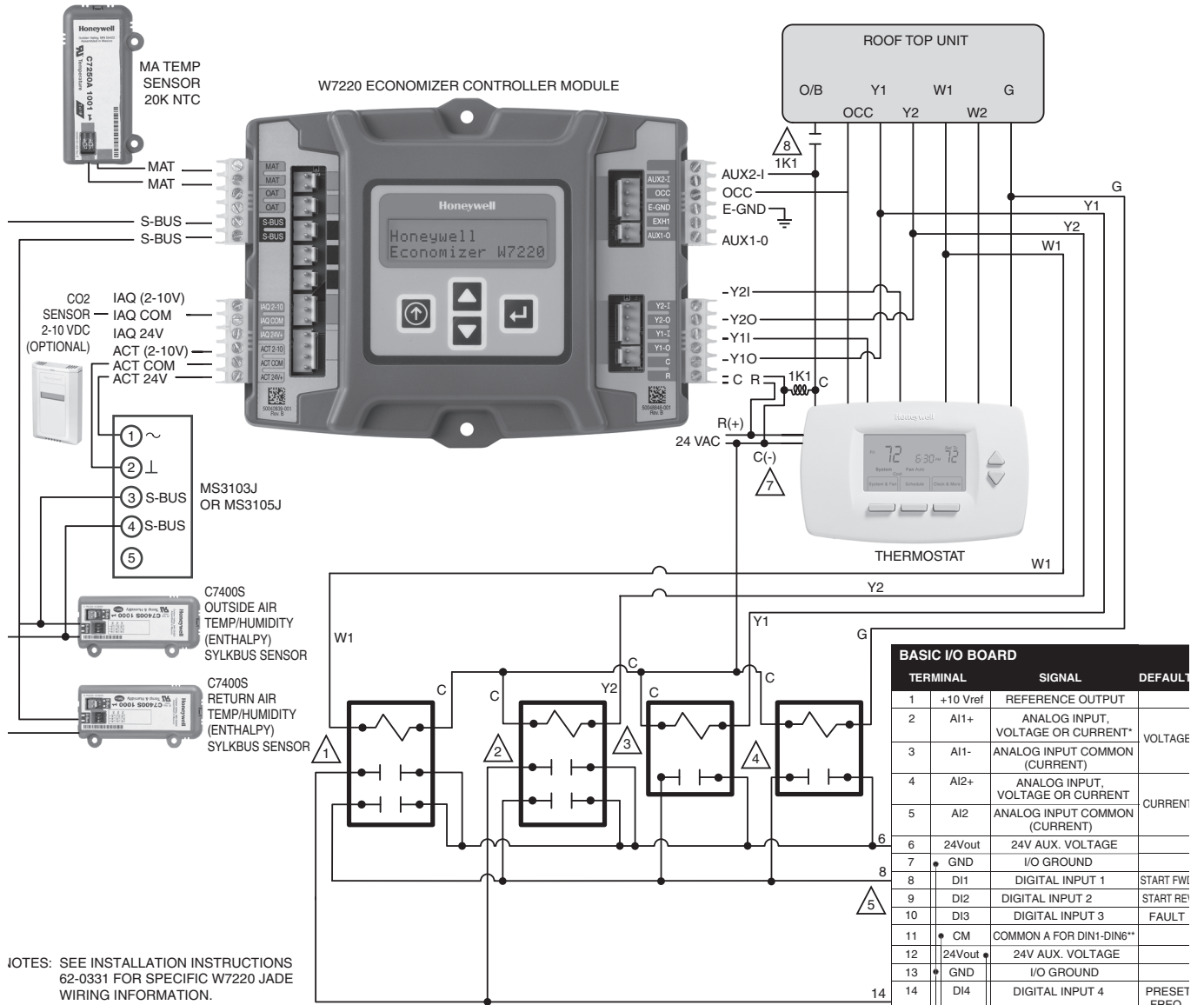

Fig. 12. Prestige and EIM with communicating actuator.



NOTES: SEE INSTALLATION INSTRUCTIONS 62-0331 FOR SPECIFIC W7220 JADE WIRING INFORMATION.

- 1 RELAY 1, DPDT RELAY, NO CONTACTS ENERGIZE DIGITAL INPUT 4 FOR HIGH SPEED FAN WITH W1 CALL.
- 2 RELAY 2, DPST RELAY, NO CONTACTS ENERGIZE DIGITAL INPUT 4 FOR HIGH SPEED FAN WITH Y2 CALL.
- 3 RELAY 3, SPST RELAY, NO CONTACTS ENERGIZE DIGITAL INPUT 1 FOR LOW SPEED FAN WITH Y1 CALL.
- 4 RELAY 4, SPST RELAY, NO CONTACTS ENERGIZE DIGITAL INPUT 1 FOR LOW SPEED FAN WITH G CALL.
- 5 LOW SPEED FAN IS CONFIGURED BY SETTING "MINIMUM FREQUENCY" WITH PARAMETER M1.8 OF THE STARTUP WIZARD OF THE SMARTVFD HVAC.
- 6 HIGH SPEED FAN IS CONFIGURED BY SETTING "PRESET FREQUENCY 1" WITH PARAMETER M3.3.12 OF THE SMARTVFD HVAC.
- 7 WHEN USING A HEAT PUMP THERMOSTAT, THERMOSTAT TERMINALS MAY DIFFER: W1 MAY BE LABELED O OR B AND W2 MAY BE LABELED W.
- 8 WHEN USING A HEAT PUMP WITH DEFROST FEEDBACK, ADD AN ISOLATION RELAY BETWEEN O AND C.

BASIC I/O BOARD			
TERMINAL	SIGNAL	DEFAULT	
1	+10 Vref	REFERENCE OUTPUT	
2	AI1+	ANALOG INPUT, VOLTAGE OR CURRENT*	VOLTAGE
3	AI1-	ANALOG INPUT COMMON (CURRENT)	CURRENT
4	AI2+	ANALOG INPUT, VOLTAGE OR CURRENT	
5	AI2-	ANALOG INPUT COMMON (CURRENT)	
6	24Vout	24V AUX. VOLTAGE	
7	GND	I/O GROUND	
8	DI1	DIGITAL INPUT 1	START FW
9	DI2	DIGITAL INPUT 2	START RE
10	DI3	DIGITAL INPUT 3	FAULT
11	CM	COMMON A FOR DIN1-DIN6**	
12	24Vout	24V AUX. VOLTAGE	
13	GND	I/O GROUND	
14	DI4	DIGITAL INPUT 4	PRESET FREQ SELECT
15	DI5	DIGITAL INPUT 5	PRESET FREQ SELECT
16	DI6	DIGITAL INPUT 6	FAULT RESE
17	C	COMMON A FOR DIN1-DIN6**	
18	AO1	ANALOG SIGNAL (+OUTPUT)	
19	AO/GND	ANALOG OUTPUT COMMON	OP FREQ
30	+24 Vin	24V AUXILIARY INPUT VOLTAGE	
A	RS485	DIFFERENTIAL RECEIVER/TRANSMITTER	
B	RS485	DIFFERENTIAL RECEIVER/TRANSMITTER	

I/O BOARD ON SMARTVFD HVAC DRIVE HVFSDS

M35159.

Fig. 13. Jade with Prestige IAQ thermostat, communicating actuator, CO2 and VFD.

JADE™ ECONOMIZER MODULE

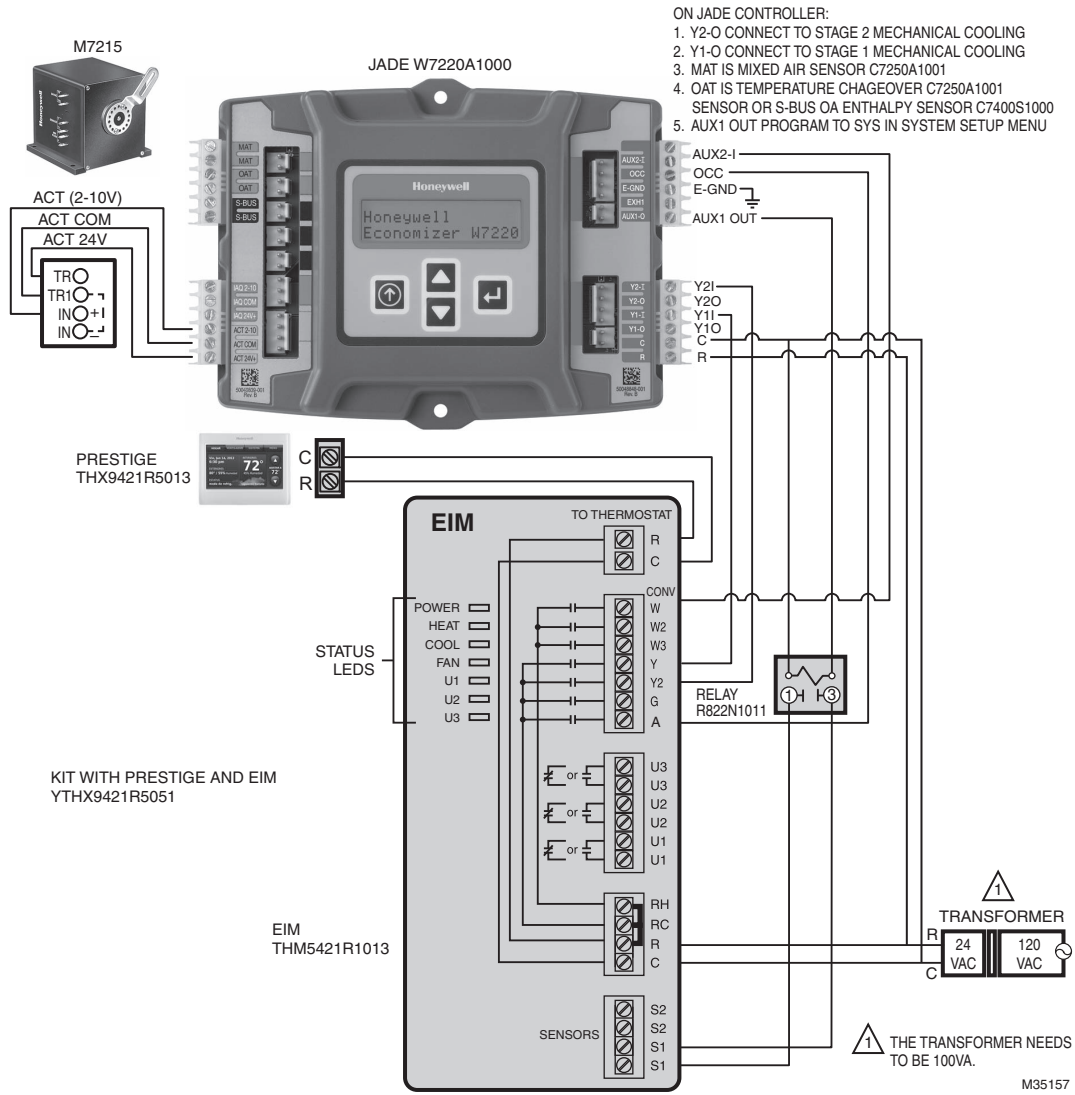

Fig. 14. Jade with Prestige IAQ thermostat and EIM, communicating actuator, CO2 and VFD.

EXH1 and EXH2 wiring:

Relay Digital Output Rating at 30 Vac (maximum power from Class 2 input only): 1.5A run;
 3.5A inrush @ 0.45PF (200,000 cycles) or
 7.5A inrush @ 0.45PF (100,000 cycles)

If the inrush or FLA amps is above listed limits OR if the fan is a line voltage fan, an external relay will be required.

If no relay is required, the EXH1 or AUX1 out is wired to one side of the fan and the other side is wired to system common "C" on the W7220 or equipment terminal board. (W7220 powered off the system transformer).

If a relay is required, the coil of the relay would be wired between the EXH1 or AUX1 and the C terminal of the W7220.

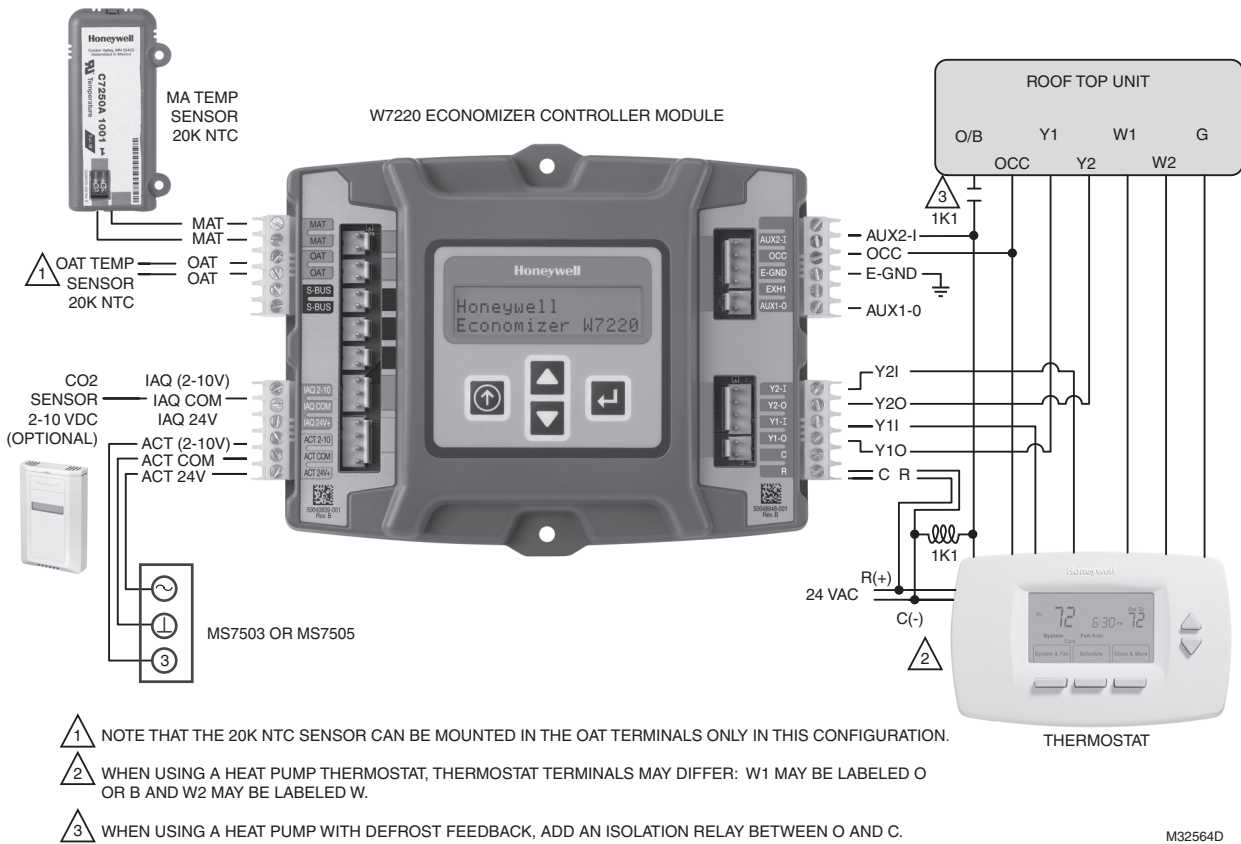
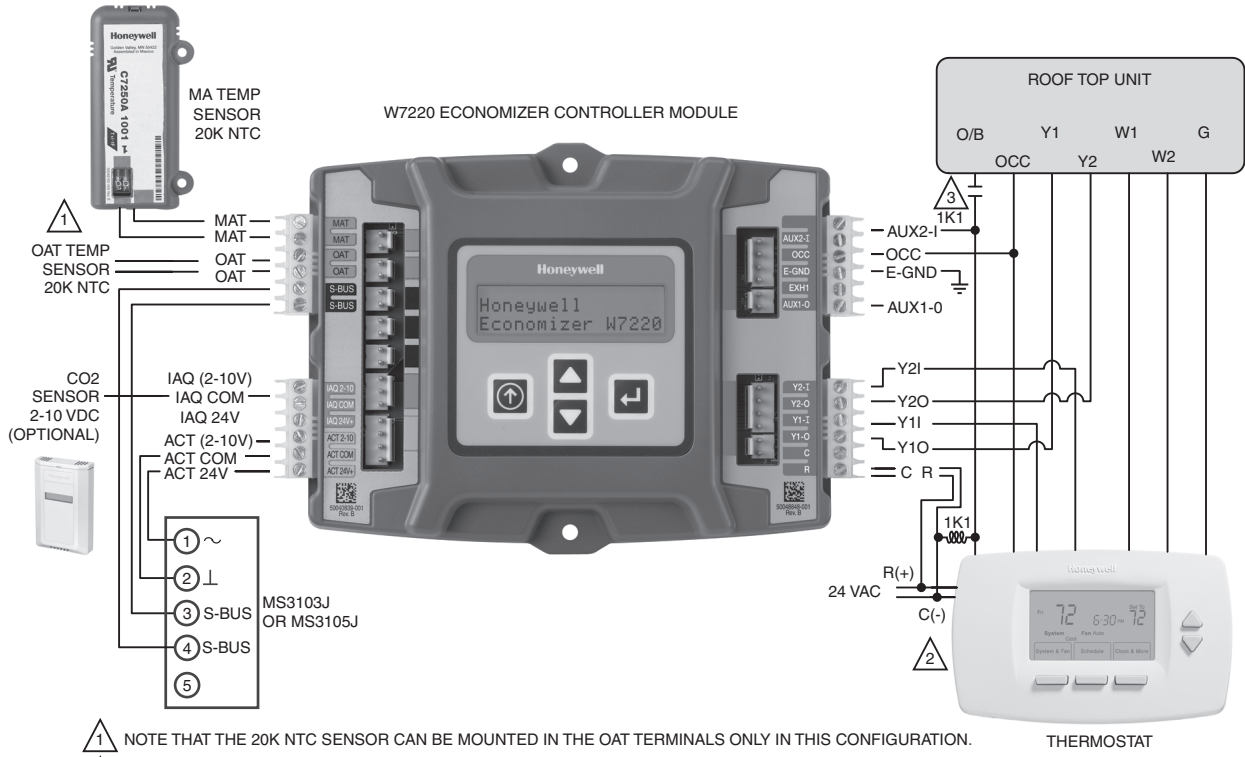

Fig. 15. Stand-alone dry-bulb Economizer configuration with Honeywell MS7503 or MS7505 Direct Coupled Actuator.



- 1 NOTE THAT THE 20K NTC SENSOR CAN BE MOUNTED IN THE OAT TERMINALS ONLY IN THIS CONFIGURATION.
- 2 WHEN USING A HEAT PUMP THERMOSTAT, THERMOSTAT TERMINALS MAY DIFFER: W1 MAY BE LABELED O OR B AND W2 MAY BE LABELED W.
- 3 WHEN USING A HEAT PUMP WITH DEFROST FEEDBACK, ADD AN ISOLATION RELAY BETWEEN O AND C.

M32650D

Fig. 16. Stand-alone dry-bulb Economizer configuration with Honeywell MS3103J or MS3105J communicating actuators.

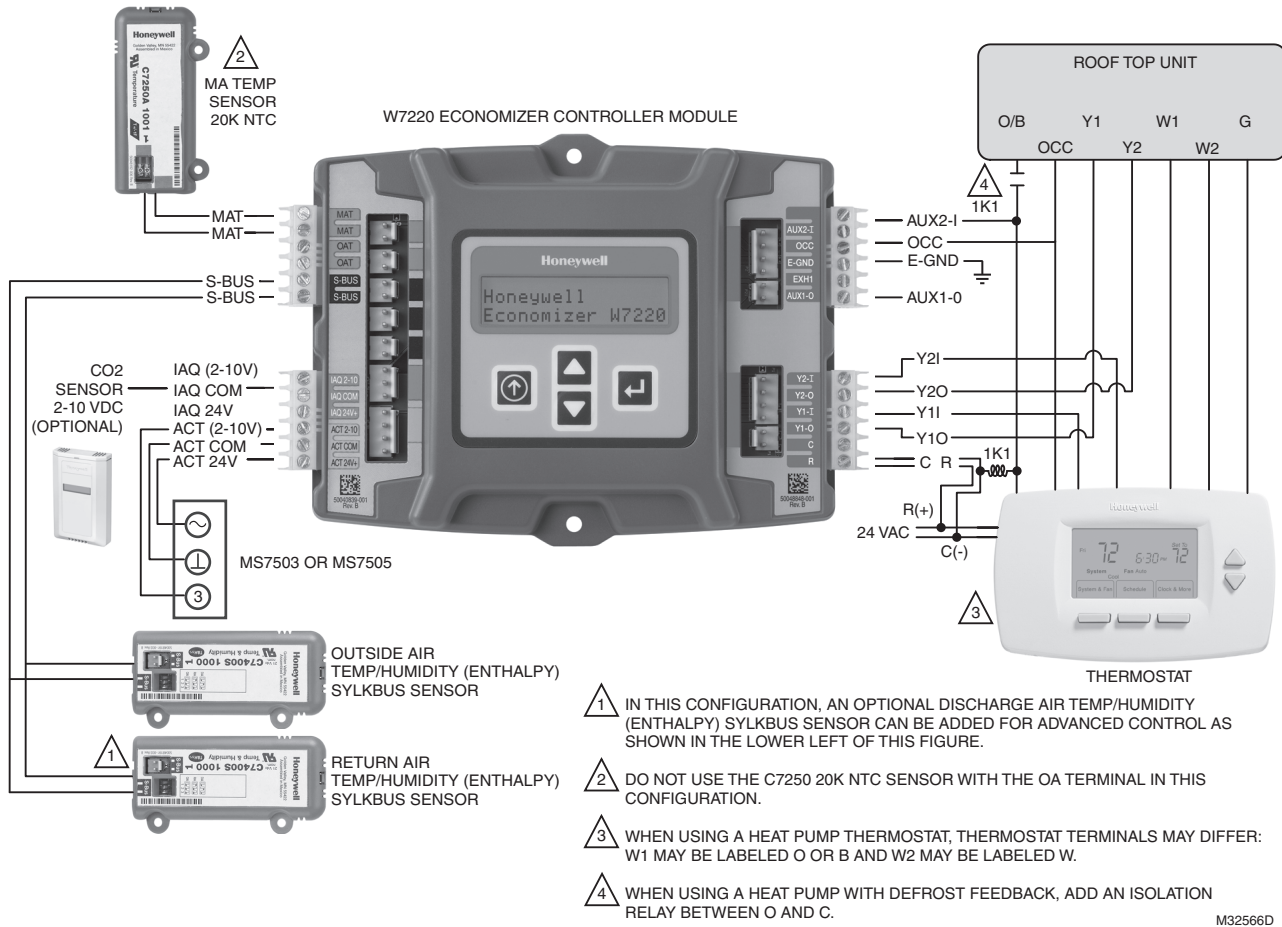

M32566D

Fig. 18. Economizer with Sylk Bus sensors for enthalpy configuration with a Honeywell MS7503 or MS7505 Direct Coupled Actuator.

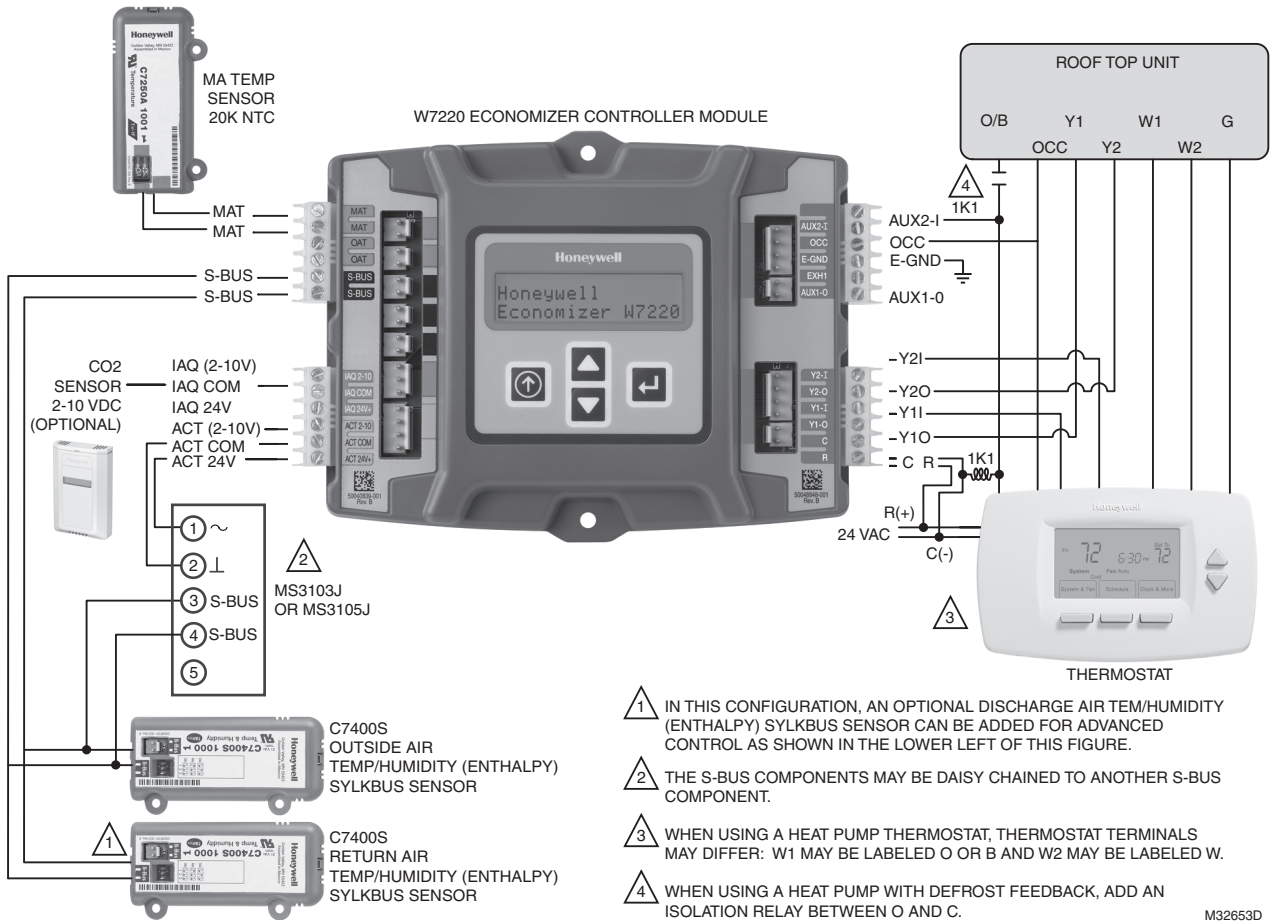

Fig. 19. Economizer with Sylk Bus sensors for enthalpy configuration with a Honeywell MS3103J or MS3105J communicating actuators.

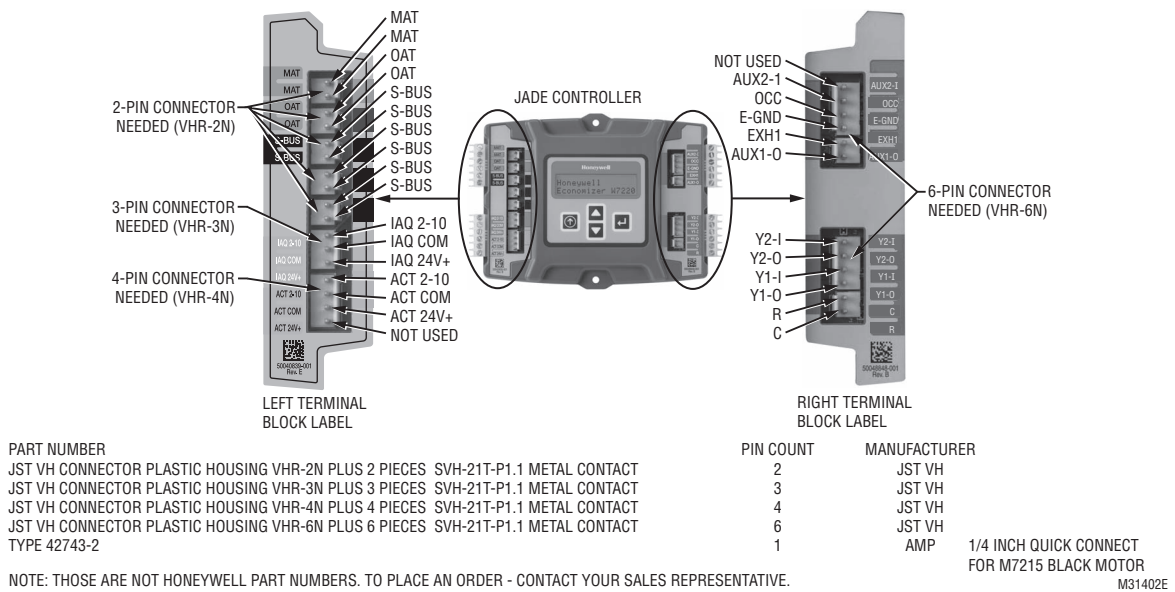

Fig. 20. OEM wiring harness information. Refer to previous wiring diagrams for detailed application wiring.

INTERFACE OVERVIEW

This section describes how to use the Economizer's user interface for:

- Keypad and menu navigation
- Settings and parameter changes
- Menu structure and selection

User Interface

The user interface consists of an LCD display and a 4-button keypad on the front of the Economizer module. The LCD is a 16 character by 2 line dot matrix display.

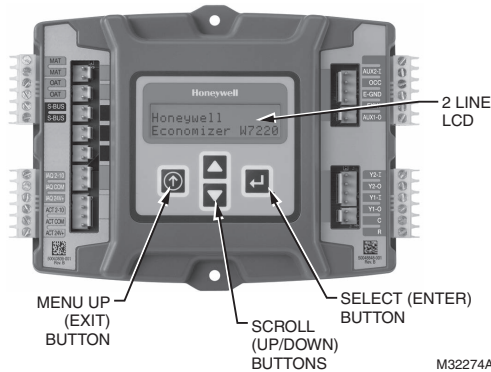

Fig. 21. Economizer LCD and Keypad Layout.

Keypad

The four navigation buttons illustrated in Fig. 21 are used to scroll through the menus and menu items, select menu items, and to change parameter and configuration settings.

Using the Keypad with Menus

To use the keypad when working with menus:

- Press the ▲ button to move to the previous menu.
- Press the ▼ button to move to the next menu.
- Press the ↵ button (Enter) to display the first item in the currently displayed menu.
- Press the ⬆ button (Menu up) to exit a menu's item and return to the list of menus.

Using the Keypad with Settings and Parameters

To use the keypad when working with Setpoints, System and Advanced Settings, Checkout tests, and Alarms:

- Navigate to the desired menu.
- Press the ↵ button (Enter) to display the first item in the currently displayed menu.
- Use the ▲ and ▼ buttons to scroll to the desired parameter.
- Press the ↵ button (Enter) to display the value of the currently displayed item.

- Press the ▲ button to increase (change) the displayed parameter value.^a
- Press the ▼ button to decrease (change) the displayed parameter value.^a
- Press the ↵ button to accept the displayed value and store it in non-volatile RAM.
- CHANGE STORED displays.
- Press the ⬆ button (MenuUp/Exit) to return to the previous menu.

^a When values are displayed, pressing and holding the ▲ or ▼ button causes the display to automatically increment.

Menu Structure

Table 5 on page 19 illustrates the complete hierarchy of menus and parameters for the JADE™ Economizer system.

The Menus in display order are:

- STATUS
- SETPOINTS
- SYSTEM SETUP
- ADVANCED SETUP
- CHECKOUT
- ALARMS

IMPORTANT

Table 5 on page 19 illustrates the complete hierarchy. Your menu parameters will be different depending on your configuration.

For example if you do not have a DCV (CO₂) sensor, then none of the DCV parameters appear and only MIN POS will display. If you have a CO₂ sensor, the DCV MIN and DCV MAX will appear AND if you have 2 speed fan DCV MIN (high and low speed) and DCV MAX (high and low speed will appear).

SETUP AND CONFIGURATION

Before being placed into service, the JADE™ Economizer module must be setup and configured for the installed system.

IMPORTANT

During setup, the Economizer module is live at all times.

The setup process uses a hierarchical menu structure that is easy to use. You press the ▲ and ▼ arrow buttons to move forward and backward through the menus and press the ↵ button to select and confirm setup item changes.

Time-out and Screensaver

When no buttons have been pressed for 10 minutes, the LCD displays a screen saver, which cycles through the Status items. Each Status items displays in turn and cycles to the next item after 5 seconds.

Table 5. Menu Structure^a.

Menu	Parameter	Parameter Default Value	Parameter Range and Increment ^b	Notes
STATUS	ECON AVAIL	NO	YES/NO	YES = economizing available; the system can use Outdoor Air for free cooling when required.
	ECONOMIZING	NO	YES/NO	YES = Outdoor Air being used for 1 st stage cooling.
	OCCUPIED	NO	YES/NO	YES = OCC signal received from space thermostat or unitary controller. YES = 24 Vac on terminal OCC No = 0 Vac on terminal OCC.
	HEAT PUMP	n/a ^c	COOL HEAT	Displays COOL or HEAT when system is set to heat pump (non-conventional)
	COOL Y1-IN	OFF	ON/OFF	Y1-I signal from space thermostat or unitary controller for cooling stage 1. ON = 24 Vac on term Y1-I OFF = 0 Vac on term Y1-I
	COOL Y1-OUT	OFF	ON/OFF	Cool Stage 1 Relay Output to mechanical cooling (Y1-OUT terminal).
	COOL Y2-IN	OFF	ON/OFF	Y2-I signal from space thermostat or unitary controller for second stage cooling. ON = 24 Vac on term Y2-I OFF = 0 Vac on term Y2-I
	COOL Y2-OUT	OFF	ON/OFF	Cool Stage 2 Relay Output to mechanical cooling (Y2-OUT terminal).
	MA TEMP	--- °F	-40 to 150 °F	Displays value of measured mixed air from MAT sensor. Displays --. if not connected, short, or out-of-range.
	DA TEMP	--- °F	-40 to 150 °F	Displays when Discharge Air Sylk Bus sensor is connected and displays measured discharge air temperature. Displays --.°F if sensor sends invalid value, if not connected, short or out-of-range.
	OA TEMP	--- °F	-40 to 140 °F	Displays measured value of outdoor air temperature. Displays --°F if sensor sends invalid value, if not connected, short or out-of-range.
	OA HUM	-- %	0 to 100%	Displays measured value of outdoor humidity from OA Sylkbus sensor. Displays --% if not connected, short, or out-of-range.
	RA TEMP	--- °F	0 to 140 °F	Displays measured value of return air temperature from RA Sylkbus sensor. Displays --°F if sensor sends invalid value, if not connected, short or out-of-range.
	RA HUM	-- %	0 to 100%	Displays measured value of return air humidity from RA Sylkbus sensor. Displays --% if sensor sends invalid value, if not connected, short or out-of-range.
	IN CO2	--- ppm	0 to 2000 ppm	Displays value of measured CO2 from CO2 sensor. Invalid if not connected, short or out-of-range. May be adjusted in Advanced menu by Zero offset and Span. See note on page 6 concerning C7632 sensor.
	DCV STATUS	n/a	ON/OFF	Displays ON if above setpoint and OFF if below setpoint, and ONLY if a CO2 sensor is connected.
	DAMPER OUT	2.0V	2.0 to 10.0 V	Displays output voltage or position to the damper actuator. ^e
	ACT POS	n/a	0 to 100%	Displays actual position of actuator.
	ACT COUNT	n/a	1 to 65,535	Displays number of times actuator has cycled. 1 Cycle equals the sum of 180° of movement in any direction.
	ACTUATOR	n/a	OK/Alarm (on Alarm menu)	Displays Error if voltage or torque is below actuator range
EXH1 OUT	OFF	ON/OFF	Output of EXH1 terminal. Displays ON when damper position reaches programmed percentage setpoint. ON = 24 Vac Output; OFF = No Output.	

Table 5. Menu Structure^a. (Continued)

Menu	Parameter	Parameter Default Value	Parameter Range and Increment^b	Notes
STATUS CONTINUE D	EXH2 OUT	OFF	ON/OFF	Output of AUX1 0 terminal Displays ON when damper position reaches programmed percentage setpoint ON = 24 Vac Output, OFF = No Output; displays only if AUX1 0 = EXH2
	ERV	OFF	ON/OFF	Output of AUX1 0 terminal, ON = 24 Vac Output, OFF = No Output; displays only if AUX1 0 = ERV
	MECH COOL ON or HEAT STAGES ON	0	0, 1, or 2	Displays number of mechanical cooling stages that are active. Displays the stage of heat pump heating that is active.
	FAN SPEED	n/a	LOW or HIGH	Displays speed of fan on a 2-speed fan unit
	W (HEAT IN)	n/a	ON/OFF	Displays status of heat on a 2-speed fan unit.

Table 5. Menu Structure^a. (Continued)

Menu	Parameter	Parameter Default Value	Parameter Range and Increment ^b	Notes	
SETPOINTS	MAT SET	53°F	38 to 70 °F; increment by 1	The economizer will modulate the OA damper to maintain the mixed air temperature at the setpoint.	
	LOW T LOCK	32°F	-45 to 80 °F; increment by 1	Setpoint determines outdoor temperature when the mechanical cooling cannot be turned on. Commonly referred to as the Compressor lockout. At or below the setpoint the Y1-O and Y2-O will not be energized on the controller.	
	DRYBLB SET	63°F	48 to 80 °F; increment by 1	<i>Dry bulb setpoint will only appear if using dry bulb change over.</i> Setpoint determines where the economizer will assume outdoor air temperature is good for free cooling; e.g.; at 63 °F setpoint unit will economize at 62 °F and below and not economize at 64 °F and above. There is a 2 °F deadband.	
	DRYBLB DIF Available firmware 1.15, June 2018, and later.	0°F	0 to 6°F; increment by 2	Drybulb Differential will only show if using dual drybulb, i.e., when an outdoor air temperature sensor C7250 is attached to OAT terminals, and a C7400S sensor is wired to S-Bus and configured for RAT (return air). Free cooling will be assumed whenever OA Temp is below <i>RAT minus this drybulb differential setting.</i>	
	ENTH CURVE	ES3	ES1, ES2, ES3, ES4, or ES5	<i>ES curve will only appear if using enthalpy changeover.</i> Enthalpy boundary "curves" for economizing using single enthalpy. See page 22 for description of enthalpy curves.	
	DCV SET	1100ppm	500 to 2000 ppm increment by 100	Displays ONLY if a CO2 sensor is connected. Setpoint for Demand Control Ventilation of space. Above the setpoint, the OA dampers will modulate open to bring in additional OA to maintain a space ppm level below the setpoint.	
	MIN POS	2.8 V	2 to 10 Vdc	Displays ONLY if a CO2 sensor is NOT connected.	
				With 2-speed fan units MIN POS L (low speed fan) and MIN POS H (high speed fan) settings are required. Default for MIN POS L is 3.2V and MIN POS H is 2.8V.	
	VENTMAX	2.8 V	2 to 10 Vdc	Displays only if a CO2 sensor is connected. Used for Vbz (ventilation max cfm) setpoint. VENTMAX is the same setting as MIN POS would be if you did not have the CO2 sensor.	
				100 to 9990 cfm increment by 10	If OA, MA RA and CO2 sensors are connected and DCV CAL ENABLE is set to AUTO mode, the OA dampers are controlled by CFM and displays from 100 to 9990 cfm.
				2 to 10 Vdc	With 2-speed fan units VENTMAX L (low speed fan) and VENTMAX H (high speed fan) settings are required. Default for VENTMAX L is 3.2V and VENTMAX H is 2.8V.
	VENTMIN	2.25 V	2 to 10 Vdc	Displays only if CO2 sensor is connected. Used for Va (ventilation min cfm) setpoint. This is the ventilation requirement for less than maximum occupancy of the space.	
				100 to 9990 cfm increment by 10	If OA, MA RA and CO2 sensors are connected and DCV CAL ENABLE is set to AUTO mode, the OA dampers are controlled by CFM and displays from 100 to 9990 cfm.
2 to 10 Vdc				With 2-speed fan units VENTMIN L (low speed fan) and VENTMIN H (high speed fan) settings are required. Default for VENTMIN L is 2.5V and VENTMIN H is 2.25V.	
ERV OAT SP ^d	32°F	0 to 50 °F; increment by 1	Only when AUX1 0 = ERV		

Table 5. Menu Structure^a. (Continued)

Menu	Parameter	Parameter Default Value	Parameter Range and Increment^b	Notes
SETPOINTS CONTINUE D	EXH1 SET	50%	0 to 100%; increment by 1	Setpoint for OA damper position when exhaust fan 1 is powered by the economizer. With 2-speed fan units Exh1 L (low speed fan) and Exh1 H (high speed fan) settings are required. Default for Exh1 L is 65% and Exh1 H is 50%
	EXH2 SET	75%	0 to 100%; increment by 1	Setpoint for OA damper position when exhaust fan 2 is powered by the economizer. Only used when AUX1 0 is set to EHX2. With 2-speed fan units Exh2 L (low speed fan) and Exh2 H (high speed fan) settings are required. Default for Exh2 L is 80% and Exh2 H is 75%
SYSTEM SETUP	INSTALL	01/01/11		Display order = MM/DD/YY Setting order = DD, MM, then YY.
	UNITS DEG	°F	°F or °C	Sets economizer controller in degrees Fahrenheit or Celsius.
	EQUIPMENT	CONV	CONV HP	CONV = conventional. HP O/B = Enables Heat Pump mode. Use AUX2 I for Heat Pump input from thermostat or controller.
	AUX2 IN	Heat (W1) ^g Note: If field factory default is available, AUX2 IN will default back to Shutdown (SD).	Shutdown (SD) Heat (W1) HP(O) HP(B)	In CONV mode: SD = Enables configuration of shutdown (default); W = Informs controller that system is in heating mode. NOTE: If using 2-speed fan mode, you must program CONV mode for W. Shutdown is not available in the two-speed fan mode. In HP O/B mode: HP(O) = energize heat pump on Cool (default); HP(B) = energize heat pump on Heat.
	FAN SPEED	2 speed ^h Note: If field factory default is available, FAN SPEED will default back to 1-speed.	1 speed/ 2 speed	Sets economizer controller for operation of 1 speed or 2 speed supply fan. The controller does not control the fan but positions the OA and RA dampers to the heating or cooling mode. See page 23 for modes and position. NOTE: 2-speed fan option also needs Heat (W1) programmed in AUX 2 In.
	FAN CFM	5000cfm	100 to 50000 cfm; increment by 100	This is the capacity of the RTU. The value is found on the label from the RTU manufacturer. The cfm of the fan is only used with DCV CAL ENABLE AU0
	AUX1 OUT	NONE	NONE ERV EXH2 SYS	<ul style="list-style-type: none"> • NONE = not configured (output is not used) • ERV= Energy Recovery Ventilator^d • EXH2 = second damper position 24 Vac out for second exhaust fan. • SYS = use output as an alarm signal
	OCC	INPUT	INPUT or ALWAYS	When using a setback thermostat with occupancy out (24 Vac), the 24 Vac is input "INPUT" to the OCC terminal. If no occupancy output from the thermostat then change program to "ALWAYS" OR add a jumper from terminal R to OCC terminal.
FACTORY DEFAULT	NO	NO or YES	Resets all set points to factory defaults when set to YES. LCD will briefly flash YES and change to NO but all parameters will change to factory default values.	

Table 5. Menu Structure^a. (Continued)

Menu	Parameter	Parameter Default Value	Parameter Range and Increment^b	Notes
ADVANCED SETUP	MA LO SET	45 °F	35 to 65 °F; increment by 1°	Temp to activate Freeze Protection (close damper or modulate to MIN POS if temp falls below set value)
	FREEZE POS	CLO	CLO MIN	Damper position when freeze protection is active (closed or MIN POS).
	CO2 ZERO	0ppm	0 to 500 ppm; increment by 10	CO2 ppm level to match CO2 sensor start level.
	CO2 SPAN	2000ppm	1000 to 3000 ppm; increment by 50	CO2 ppm span to match CO2 sensor; e.g.; 500-1500 sensor output would be 500 CO2 zero and 1000 CO2 span. See note on page 6 for C7632 CO2 sensor.
	STG3 DLY	2.0h	0 min, 5 min, 15 min, then 15 min intervals. Up to 4h or OFF	Delay after stage 2 for cool has been active. Turns on 2nd stage of mechanical cooling when economizer is 1st stage call and mechanical cooling is 2nd stage call. Allows three stages of cooling, 1 economizer and 2 mechanical. OFF = no Stage 3 cooling.
	SD DMPR POS	CLO	CLO OPN	Indicates shutdown signal from space thermostat or unitary controller. When controller receives 24 Vac input on the SD terminal in conventional mode, the OA damper will open if programmed for OPN and OA damper will close if programmed for CLO. All other controls, e.g., Y1-O, Y2-O, EXH1, etc. will shut off.
	DA LO ALM	45 °F	NONE 35°F to 65°F in 5°F increments	Used for alarm for when the DA air temperature is too low. Set lower range of alarm, below this temperature the alarm will show on the display.
	DA HI ALM	80 °F	NONE 70 °F to 180 °F in 5° F increments	Used for alarm for when the DA air temperature is too high. Set high range of alarm, above this temperature the alarm will show on the display
	DCVCAL ENA	MAN	MAN (manual) AUTO	Turns on the DCV automatic control of the dampers. Resets ventilation based on the RA, OA and MA sensor conditions. Requires all sensors (RA, OA, MA and CO2). This operation is not operable with a 2-speed fan unit.
	MAT T CAL	0.0 F°	+/-2.5F°	Allows for the operator to adjust for an out of calibration temperature sensor
	OAS T CAL	0.0F°	+/-2.5F°	Allows for the operator to adjust for an out of calibration temperature sensor
	OAS H CAL	0% RH	+/-10% RH	Allows for the operator to adjust for an out of calibration humidity sensor
	RA T CAL	0.0F°	+/-2.5F°	Allows for the operator to adjust for an out of calibration temperature sensor
	RA H CAL	0% RH	+/-10% RH	Allows for the operator to adjust for an out of calibration humidity sensor
	DA T CAL	0.0 F°	+/-2.5F°	Allows for the operator to adjust for an out of calibration temperature sensor
2SP FAN DELAY	5 Minutes	0 to 20 minutes in 1 minute increments.	When in economizing mode this is the delay for the high speed fan to try to satisfy the call for second stage cooling before the first stage mechanical cooling is enabled.	

Table 5. Menu Structure^a. (Continued)

Menu	Parameter	Parameter Default Value	Parameter Range and Increment^b	Notes
CHECKOUT ^f	DAMPER MINIMUM POSITION	n/a	n/a	The checkout for the damper minimum positions is based on the system. See Table 6.
	DAMPER OPEN	n/a	n/a	Positions damper to the full open position. Exhaust fan contacts enable during the DAMPER OPEN test. Make sure you pause in this mode to allow for exhaust contacts to energize due to the delay in the system.
	DAMPER CLOSE	n/a	n/a	Positions damper to the fully closed position.
	CONNECT Y1-O	n/a	n/a	Closes the Y1-O relay (Y1-O). See CAUTION on page 31
	CONNECT Y2-O	n/a	n/a	Closes the Y2-O relay (Y2-O). See CAUTION on page 31
	CONNECT AUX1-O	n/a	n/a	Energizes the AUX1-O output. If AUX1-O setting is: <ul style="list-style-type: none"> • NONE – no action taken • ERV – 24 Vac out. Turns on or signals an ERV that the conditions are not good for economizing but are good for ERV operation.^d • SYS – 24 Vac out. Issues a system alarm.
	CONNECT EXH1	n/a	n/a	Closes the power exhaust fan 1 relay (EXH1)
ALARMS(#)				Alarms display only when they are active. The menu title "ALARMS (#)" includes the number of active alarms in parenthesis (). When using SYLK bus sensors, "SYLK" will appear on the screen, and when using 20k OA temperature sensors, "SENS T" will appear on the screen.
	MA T SENS ERR	n/a	n/a	Mixed air sensor has failed or become disconnected - check wiring then replace sensor if the alarm continues
	CO2 SENS ERR	n/a	n/a	CO2 sensor has failed, gone out of range or become disconnected - check wiring then replace sensor if the alarm continues
	OA SYLK T ERR	n/a	n/a	Outdoor air enthalpy sensor has failed or become disconnected - check wiring then replace sensor if the alarm continues
	OA SYLK H ERR	n/a	n/a	
	RA SYLK T ERR	n/a	n/a	Return air enthalpy sensor has failed or become disconnected - check wiring then replace sensor if the alarm continues
	RA SYLK H ERR	n/a	n/a	
	DA SYLK T ERR	n/a	n/a	Discharge air sensor has failed or become disconnected - check wiring then replace sensor if the alarm continues
	OA SENS T ERR	n/a	n/a	Outdoor air temperature sensor has failed or become disconnected - check wiring then replace sensor if the alarm continues
	ACT ERROR	n/a	n/a	Actuator has failed or become disconnected - check for stall, over voltage, under voltage and actuator count. Replace actuator if damper is moveable and supply voltage is between 21.6 V and 26.4 V. Check actuator count on STATUS menu.
	FREEZE ALARM	n/a	n/a	Check if outdoor temperature is below the LOW Temp Lockout on setpoint menu. Check if Mixed air temperature on STATUS menu is below the Lo Setpoint on Advanced setup menu. When conditions are back in normal range then the alarm will go away.
	SHUTDOWN ACTIVE	n/a	n/a	AUX2 IN is programmed for SHUTDOWN and 24 V has been applied to AUX 2IN terminal
	DMP CAL RUNNING	n/a	n/a	If DCV Auto enable has been programmed, when the Jade is completing a calibration on the dampers, this alarm will display. Wait until the calibration is completed and the alarm will go away. Must have OA, MA and RA sensors for DCV calibration; set up is in the Advanced setup menu
	DA SENS ALM	n/a	n/a	Discharge air temperature is out of the range set in the ADVANCED SETUP Menu. Check the temperature of the discharge air.

Table 5. Menu Structure^a. (Continued)

Menu	Parameter	Parameter Default Value	Parameter Range and Increment ^b	Notes
ALARMS(#) CONTINUE D	SYS ALARM	n/a	n/a	When AUX1-0 is set to SYS and there is any alarm (e.g., failed sensors, etc.), the AUX1-0 terminal has 24 Vac out.
	ACT UNDER V	n/a	n/a	Voltage received by Actuator is above expected range
	ACT OVER V	n/a	n/a	Voltage received by Actuator is below expected range
	ACT STALLED	n/a	n/a	Actuator stopped before achieving commanded position
FEATURES ADJUSTABLE ONLY BY USE OF THE W7220 PC MOD TOOL				
	ACT STALL ALARM SUPPRESSION	Disabled	Enabled or Disabled	If enabled this feature allows the operator to suppress the stall alarm in a specific range of the actuator stroke.
	SELECT TYPE OF CONTROLLER	W7220	W7220, W7218 or Pre-programmed special	The operator can configure a program for a customer or job and save the program in the file. Found on the configuration page of the Trade version
	ACTUATOR SLIPPAGE ALARM	Enabled	Enabled or Disabled	Alarms if the actuator becomes disconnected from the damper or is slipping on the shaft. If Enabled, the Jade system will complete a system air temperature check. If there is the expected change in system air temperature, then Jade assumes the actuator is connected to the damper. If the expected system air temperature changes do not occur, then an actuator slippage alarm is displayed on the Jade LCD. Found on the configuration page of the Trade version.
	ACTUATOR SLIPPAGE ALARM SENSITIVITY	Low	Low, Standard or High	Sensitivity can be set to HIGH, STANDARD or LOW. High means the system will check 5 times for the damper to move before displaying the alarm. Standard is 10 times before the alarm is displayed. Low is 20 times before the alarm is displayed. Found on the economizer page of the Trade version.
	LOCATION OF ECONOMIZER CONTROL SENSOR	Before the cooling coil	Before coil or AUTO	The operator can choose if the economizer control sensor (normally referred to as the Mixed air sensor) is placed in the mixed air (before the coil) or Auto in the case the sensor is placed after the cooling coil. Found on the configuration page of the Trade version.
	DAMPER AIA THRESHOLD	15 degrees	5 to 40 degrees	Damper threshold feature (Adaptive Integral Action) is the difference in the mixed air temperature reported by the MAT sensor and the MAT setpoint. Lower (2 degrees) transfer rate between the actual MAT sensor reading and the MAT setpoint normally means the damper is closing and opening faster. Larger transfer rate (up to 20 degrees) between the sensor reading and the setpoint normally means the damper is opening and closing slower. Used in applications where there is a large MA space or there is a long duct between the OA and the MA causing a delay. Found on the economizer page of the Trade version.

^a Table 5 illustrates the complete hierarchy. Your menu parameters may be different depending on your configuration. For example if you do not have a DCV (CO₂) sensor, then none of the DCV parameters appear.

^b When values are displayed, pressing and holding the ▲ or ▼ button causes the display to automatically increment.

^c n/a = not applicable

^d ERV Operation: When in Cooling mode AND the conditions are NOT OK for economizing - the ERV terminal will be energized. In the Heating mode the ERV terminal will be energized when the OA is below the ERV OAT setpoint in the setpoint menu.

^e When used with Honeywell communicating actuator the damper out is reported in XX.X% open versus XX.X Vdc.

^f After 10 minutes without a command or mode change, the controller will change to normal operation.

^g Default for AUX2 IN changed from SD to W1 with 1.15 firmware (June 2018).

^h Default for FAN SPEED changed from 1-speed to 2-speed with 1.15 firmware (June 2018).

Table 6. Damper minimum position settings and readings on checkout menu.

Fan Speed	Demand Control Ventilation (CO2 Sensor)	Setpoints	Checkout
1	NO	MIN POS	VMAX-HS
1	NO	N/A	N/A
2	NO	MIN POS H	VMAX-HS
2	NO	MIN POS L	VMAX-LS
1	YES	VENT MIN	VMIN-HS
1	YES	VENT MAX	VMAX-HS
2	YES	VENT MIN H	VMIN-HS
2	YES	VENT MAX H	VMAX-LS
2	YES	VENT MINL	N/A
2	YES	VENT MAX L	N/A

SEQUENCE OF OPERATION

Table 7. Dry Bulb Operation No DCV (CO2 sensor) - 1 Speed Fan.

DCV	OA Good to economize?	Y1-I	Y2-I	FAN SPD	Y1-O	Y2-O	Occupied	Unoccupied
None	No	Off	Off	High	0-v/Off	0-v/Off	MIN POS	Closed
		On	Off	High	24-v/On	0-v/Off	MIN POS	Closed
		On	On	High	24-v/On	24-v/On	MIN POS	Closed
None	Yes	Off	Off	High	0-v/Off	0-v/Off	MIN POS	Closed
		On	Off	High	0-v/Off	0-v/Off	MIN POS to Full-Open	Closed to Full-Open
		On	On	High	24-v/On	0-v/Off ^a	MIN POS to Full-Open	Closed to Full-Open

^a With stage 3 delay (STG3 DLY) in Advanced setup menu can turn on 2nd stage of mechanical cooling Y2 -O after the delay if the call for Y1-I and Y2-I have not been satisfied.

Table 8. Dry Bulb Operation With DCV (CO2 sensor) - 1 Speed Fan.

DCV	OA Good to economize?	Y1-I	Y2-I	FAN SPD	Y1-O	Y2-O	Occupied	Unoccupied
Below CO2 set	No	Off	Off	High	0-v/Off	0-v/Off	VENTMIN	Closed
		On	Off	High	24-v/On	0-v/Off	VENTMIN	Closed
		On	On	High	24-v/On	24-v/On	VENTMIN	Closed
	Yes	Off	Off	High	0-v/Off	0-v/Off	VENTMIN	Closed
		On	Off	High	0-v/Off	0-v/Off	VENTMIN to Full-Open	Closed to Full-Open
		On	On	High	24-v/On	0-v/Off ^a	VENTMIN to Full-Open	Closed to Full-Open
Above CO2 set	No	Off	Off	High	0-v/Off	0-v/Off	VENTMIN to VENTMAX	Closed
		On	Off	High	24-v/On	0-v/Off	VENTMIN to VENTMAX	Closed

DCV	OA Good to economize?	Y1-I	Y2-I	FAN SPD	Y1-O	Y2-O	Occupied	Unoccupied
		On	On	High	24-v/On	24-v/On	VENTMIN to VENTMAX	Closed
	Yes	Off	Off	High	0-v/Off	0-v/Off	VENTMIN to VENTMAX	Closed
		On	Off	High	0-v/Off	0-v/Off	VENTMIN to Full-Open	Closed to Full-Open
		On	On	High	24-v/On	0-v/Off ^a	VENTMIN to Full-Open	Closed to Full-Open

^a With stage 3 delay (STG3 DLY) in Advanced setup menu can turn on 2nd stage of mechanical cooling Y2 –O after the delay if the call for Y1-I and Y2-I have not been satisfied.

Table 9. Enthalpy Operation No DCV (CO2 sensor) - 1 Speed Fan.

DCV	OA Good to economize?	Y1-I	Y2-I	FAN SPD	Y1-O	Y2-O	Occupied	Unoccupied
None	No	Off	Off	High	0-v/Off	0-v/Off	MIN POS	Closed
		On	Off	High	24-v/On	0-v/Off	MIN POS	Closed
		On	On	High	24-v/On	24-v/On	MIN POS	Closed
None	Yes	Off	Off	High	0-v/Off	0-v/Off	MIN POS	Closed
		On	Off	High	0-v/Off	0-v/Off	MIN POS to Full-Open	Closed to Full-Open
		On	On	High	24-v/On	0-v/Off ^a	MIN POS to Full-Open	Closed to Full-Open

^a With stage 3 delay (STG3 DLY) in Advanced setup menu can turn on 2nd stage of mechanical cooling Y2 –O after the delay if the call for Y1-I and Y2-I have not been satisfied.

Table 10. Enthalpy Operation With DCV (CO2 sensor) - 1 Speed Fan.

DCV	OA Good to economize?	Y1-I	Y2-I	FAN SPD	Y1-O	Y2-O	Occupied	Unoccupied
Below set	No	Off	Off	High	0-v/Off	0-v/Off	VENTMIN	Closed
		On	Off	High	24-v/On	0-v/Off	VENTMIN	Closed
		On	On	High	24-v/On	24-v/On	VENTMIN	Closed
	Yes	Off	Off	High	0-v/Off	0-v/Off	VENTMIN	Closed
		On	Off	High	0-v/Off	0-v/Off	VENTMIN to Full-Open	Closed to Full-Open
		On	On	High	24-v/On	0-v/Off ^a	VENTMIN to Full-Open	Closed to Full-Open
Above set	No	Off	Off	High	0-v/Off	0-v/Off	VENTMIN to VENTMAX	Closed
		On	Off	High	24-v/On	0-v/Off	VENTMIN L to VENTMAX	Closed
		On	On	High	24-v/On	24-v/On	VENTMIN H to VENTMAX	Closed
	Yes	Off	Off	High	0-v/Off	0-v/Off	VENTMIN L to VENTMAX	Closed
		On	Off	High	0-v/Off	0-v/Off	VENTMIN to Full-Open	Closed to Full-Open
		On	On	High	DELAY ^b 24-v/On	0-v/Off ^a	VENTMIN to Full-Open	Closed to Full-Open

^a With stage 3 delay (STG3 DLY) in Advanced setup menu can turn on 2nd stage of mechanical cooling Y2 –O after the delay if the call for Y1-I and Y2-I have not been satisfied.

^b With 2SP FAN DELAY (Advanced Setup Menu) when in the economizing mode there is a delay for the high speed fan to try to satisfy the call for second stage cooling by turning on the fan to high and opening the OA damper 100% before the first stage mechanical cooling is enabled.

Table 11. Dry Bulb Operation No DCV (CO2 sensor) - 2 Speed Fan.

DCV	OA Good to economize?	Y1-I	Y2-I	FAN SPD	Y1-O	Y2-O	Occupied	Unoccupied
None	No	Off	Off	Low	0-v/Off	0-v/Off	MIN POS L	Closed
		On	Off	Low	24-v/On	0-v/Off	MIN POS L	Closed
		On	On	High	24-v/On	24-v/On	MIN POS H	Closed
None	Yes	Off	Off	Low	0-v/Off	0-v/Off	MIN POS L	Closed
		On	Off	Low	0-v/Off	0-v/Off	MIN POS L to Full-Open	Closed to Full-Open
		On	On	High	DELAY ^b 24-v/On	0-v/Off ^a	MIN POS H to Full-Open	Closed to Full-Open

^aWith stage 3 delay (STG3 DLY) in Advanced setup menu can turn on 2nd stage of mechanical cooling Y2 -O after the delay if the call for Y1-I and Y2-I have not been satisfied.

^bWith 2SP FAN DELAY (Advanced Setup Menu) when in the economizing mode there is a delay for the high speed fan to try to satisfy the call for second stage cooling by turning on the fan to high and opening the OA damper 100% before the first stage mechanical cooling is enabled.

Table 12. Dry Bulb Operation With DCV (CO2 sensor) - 2 Speed Fan.

DCV	OA Good to economize?	Y1-I	Y2-I	FAN SPD	Y1-O	Y2-O	Occupied	Unoccupied
Below set	No	Off	Off	Low	0-v/Off	0-v/Off	VENTMIN L	Closed
		On	Off	Low	24-v/On	0-v/Off	VENTMIN L	Closed
		On	On	High	24-v/On	24-v/On	VENTMIN H	Closed
	Yes	Off	Off	Low	0-v/Off	0-v/Off	VENTMIN L	Closed
		On	Off	Low	0-v/Off	0-v/Off	VENTMIN L to Full-Open	Closed to Full-Open
		On	On	High	24-v/On	0-v/Off ^a	VENTMIN H to Full-Open	Closed to Full-Open
Above set	No	Off	Off	Low	0-v/Off	0-v/Off	VENTMIN L to VENTMAX	Closed
		On	Off	Low	24-v/On	0-v/Off	VENTMIN L to VENTMAX	Closed
		On	On	High	24-v/On	24-v/On	VENTMIN H to VENTMAX	Closed
	Yes	Off	Off	Low	0-v/Off	0-v/Off	VENTMIN L to VENTMAX	Closed
		On	Off	Low	0-v/Off	0-v/Off	VENTMIN L to Full-Open	Closed to Full-Open
		On	On	High	DELAY ^b 24-v/On	0-v/Off ^a	VENTMIN H to Full-Open	Closed to Full-Open

^aWith stage 3 delay (STG3 DLY) in Advanced setup menu can turn on 2nd stage of mechanical cooling Y2 -O after the delay if the call for Y1-I and Y2-I have not been satisfied.

^bWith 2SP FAN DELAY (Advanced Setup Menu) when in the economizing mode there is a delay for the high speed fan to try to satisfy the call for second stage cooling by turning on the fan to high and opening the OA damper 100% before the first stage mechanical cooling is enabled.

Table 13. Enthalpy Operation No DCV (CO2 sensor) - 2 Speed Fan.

DCV	OA Good to economize?	Y1-I	Y2-I	FAN SPD	Y1-O	Y2-O	Occupied	Unoccupied
NO CO2 SENSOR	No	Off	Off	Low	0-v/Off	0-v/Off	MIN POS L	Closed
		On	Off	Low	24-v/On	0-v/Off	MIN POS L	Closed

DCV	OA Good to economize?	Y1-I	Y2-I	FAN SPD	Y1-O	Y2-O	Occupied	Unoccupied
		On	On	High	24-v/On	24-v/On	MIN POS H	Closed
	Yes	Off	Off	Low	0-v/Off	0-v/Off	MIN POS L	Closed
		On	Off	Low	0-v/Off	0-v/Off	MIN POS L to Full-Open	Closed to Full-Open
		On	On	High	DELAY ^b 24-v/On	0-v/Off ^a	MIN POS H to Full-Open	Closed to Full-Open

^aWith stage 3 delay (STG3 DLY) in Advanced setup menu can turn on 2nd stage of mechanical cooling Y2 –O after the delay if the call for Y1-I and Y2-I have not been satisfied.

^bWith 2SP FAN DELAY (Advanced Setup Menu) when in the economizing mode there is a delay for the high speed fan to try to satisfy the call for second stage cooling by turning on the fan to high and opening the OA damper 100% before the first stage mechanical cooling is enabled.

Table 14. Enthalpy Operation With DCV (CO2 sensor) - 2 Speed Fan.

DCV	OA Good to economize?	Y1-I	Y2-I	FAN SPD	Y1-O	Y2-O	Occupied	Unoccupied
Below set	No	Off	Off	Low	0-v/Off	0-v/Off	VENTMIN L	Closed
		On	Off	Low	24-v/On	0-v/Off	VENTMIN L	Closed
		On	On	High	24-v/On	24-v/On	VENTMIN H	Closed
	Yes	Off	Off	Low	0-v/Off	0-v/Off	VENTMIN L	Closed
		On	Off	Low	0-v/Off	0-v/Off	VENTMIN L to Full-Open	Closed to Full-Open
		On	On	High	24-v/On	0-v/Off ^a	VENTMIN H to Full-Open	Closed to Full-Open
Above set	No	Off	Off	Low	0-v/Off	0-v/Off	VENTMIN L to VENTMAX	Closed
		On	Off	Low	24-v/On	0-v/Off	VENTMIN L to VENTMAX	Closed
		On	On	High	24-v/On	24-v/On	VENTMIN H to VENTMAX	Closed
	Yes	Off	Off	Low	0-v/Off	0-v/Off	VENTMIN L to VENTMAX	Closed
		On	Off	Low	0-v/Off	0-v/Off	VENTMIN L to Full-Open	Closed to Full-Open
		On	On	High	DELAY ^b 24-v/On	0-v/Off ^a	VENTMIN H to Full-Open	Closed to Full-Open

^aWith stage 3 delay (STG3 DLY) in Advanced setup menu can turn on 2nd stage of mechanical cooling Y2 –O after the delay if the call for Y1-I and Y2-I have not been satisfied.

^bWith 2SP FAN DELAY (Advanced Setup Menu) when in the economizing mode there is a delay for the high speed fan to try to satisfy the call for second stage cooling by turning on the fan to high and opening the OA damper 100% before the first stage mechanical cooling is enabled.

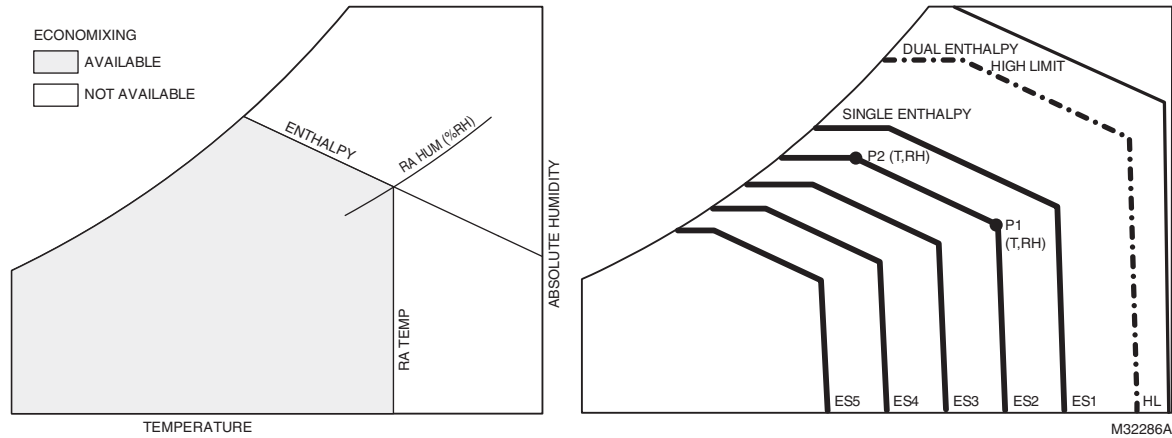

Fig. 22. Single Enthalpy curve and boundaries.

Table 15. Single Enthalpy and Dual Enthalpy High Limit Curves.

Enthalpy Curve	Temp. Dry-Bulb (°F)	Temp. Dewpoint (°F)	Enthalpy (btu/lb/da)	Point P1		Point P2	
				Temp. °F	Humidity %RH	Temp. °F	Humidity %RH
ES1	80.0	60.0	28.0	80.0	36.8	66.3	80.1
ES2	75.0	57.0	26.0	75.0	39.6	63.3	80.0
ES3	70.0	54.0	24.0	70.0	42.3	59.7	81.4
ES4	65.0	51.0	22.0	65.0	44.8	55.7	84.2
ES5	60.0	48.0	20.0	60.0	46.9	51.3	88.5
HL	86.0	66.0	32.4	86.0	38.9	72.4	80.3

Enthalpy Settings

When the OA temperature, enthalpy and dew point are below the respective setpoints, the Outdoor Air can be used for economizing. Fig. 22 shows the new single enthalpy boundaries in the W7220. There are 5 boundaries (setpoints ES1 through ES5), which are defined by dry bulb temperature, enthalpy and dew point.

Refer to Table 15 for the ENTH CURVE setpoint values.

To use enthalpy the W7220 must have a C7400S Sylkbus sensor for OA. The W7220 calculates the enthalpy and dew point using the OA temperature and humidity input from the OA sensor. When the OA temperature, OA humidity and OA dew point are all below the selected boundary, the economizer sets the economizing mode to YES, economizing is available.

When conditions are above the selected boundary, the conditions are not good to economize and the mode is set to NO.

Fig. 22 shows the 5 current boundaries. There is also a high limit boundary for differential enthalpy. The high limit boundary is ES1 when there are no stages of mechanical cooling energized and HL when a compressor stage is energized.

Table 15 provides the values for each boundary limit.

Two-Speed Fan Operation

The later versions of the W7220 Jade controller have the capability to work with a system using a 2-speed supply fan. The W7220 does not control the supply directly but uses the following input status to determine the speed of the supply fan and controls the OA damper to the required position.

State	Fan Speed
OCC	Low
Y1	Low
Y2	High
W	High

The W (heating mode) is not controlled by the W7220 but it requires the status to know where to position the OA damper for minimum position for the fan speed.

The 2 speed fan delay is available when the system is programmed for 2 speed fan (in the System Setup menu item). The 2 speed fan delay is defaulted to 5 minutes and can be changed in the Advanced Setup menu item. When the unit has a call for Y1 In and in the free cooling mode and there is a call for Y2 In, the 2-speed fan delay starts and the OA damper will modulate 100% open, the supply fan should be set to high speed by the unit controller. After the delay one of two actions will happen:

- The Y2 In call will be satisfied with the damper 100% open and fan on high speed and the call will turn off

OR

- If the call for additional cooling in the space has not been satisfied then the first stage of mechanical cooling will be enabled through Y1 Out or Y2 Out.

CHECKOUT

Inspect all wiring connections at the Economizer module's terminals, and verify compliance with the installation wiring diagrams.

For checkout, review the Status of each configured parameter and perform the Checkout tests.

NOTE: See "Interface Overview" on page 18. for information about menu navigation and use of the keypad.



WARNING

Electrical Shock Hazard.

Can cause severe injury, death or property damage.

Disconnect power supply before beginning wiring or making wiring connections, to prevent electrical shock or equipment damage.

If any wiring changes are required, first be sure to remove power from the Economizer module before starting work. Pay particular attention to verifying the power connection (24 Vac).

Power Up

After the module is mounted and wired, apply power.

Initial Menu Display

On initial start up, Honeywell displays on the first line and Economizer W7220 on the second line. After a brief pause, the revision of the software appears on the first line and the second line will be blank.

Power Loss (Outage or Brownout)

All setpoints and advanced settings are restored^a after any power loss or interruption.

^a All settings are stored in non-volatile flash memory.

Status

Use the Status menu (see Table 5) to check the parameter values for the various devices and sensors configured.

NOTE: See "Interface Overview" on page 18. for information about menu navigation and use of the keypad.

Checkout Tests

Use the Checkout menu (Table 5) to test the damper operation and any configured outputs. Only items that are configured are shown in the Checkout menu.

NOTE: See "Interface Overview" on page 18. for information about menu navigation and use of the keypad.

To perform a Checkout test:

1. Scroll to the desired test in the Checkout menu using the ▲ and ▼ buttons.
2. Press the ↵ button to select the item.
3. RUN? appears on the display.
4. Press the ↵ button to start the test.
5. The unit pauses and then displays IN PROGRESS.
6. When all parameters have been tested, press the ⏶ button (Menu up) to end the test (e.g. turn off the relay).

The checkout tests can all be performed at the time of installation or any time during the operation of the system as a test that the system is operable.



CAUTION

Equipment damage may result.

Be sure to allow enough time for compressor startup and shutdown between checkout tests so that you do not short-cycle the compressors.

TROUBLESHOOTING

Alarms

The Economizer module provides alarm messages that display on the 2-line LCD.

NOTE: Upon power up, the module waits 60 minutes before checking for alarms. This allows time for all the configured devices (e.g. sensors, actuator) to become operational. The exception is the MA sensor which will alarm immediately.

If one or more alarms are present and there has been no keypad activity for at least 5 minutes, the Alarms menu displays and cycles through the active alarms.

You can also navigate to the Alarms menu at any time.

Clearing Alarms

Once the alarm has been identified and the cause has been removed (e.g. replaced faulty sensor), the alarm can be cleared from the display.

To clear an alarm, perform the following:

1. Navigate to the desired alarm.
2. Press the ← button.
3. ERASE? displays.
4. Press the ← button.
5. ALARM ERASED displays.
6. Press the  button (MenuUp/Exit) to complete the action and return to the previous menu.

NOTE: If an the alarm still exists after you clear it, it re-displays within 5 seconds.

By using this Honeywell literature, you agree that Honeywell will have no liability for any damages arising out of your use or modification to, the literature. You will defend and indemnify Honeywell, its affiliates and subsidiaries, from and against any liability, cost, or damages, including attorneys' fees, arising out of, or resulting from, any modification to the literature by you.

Home and Building Technologies

In the U.S.:

Honeywell

715 Peachtree Street NE

Atlanta, GA 30308

customer.honeywell.com

® U.S. Registered Trademark
© 2018 Honeywell International Inc.
63-2700-11 M.S. Rev. 05-18
Printed in United States

Honeywell